

Detail hrebeňa a štítu

- D1.1. Hrebeň 1
- D1.2. Hrebeň 2
- D2.1. Štít 1
- D2.2. Štít 2
- D2.3. Štít 3 (s presahom)

Detail pultu a atiky pultovej strechy

- D3.1. Pult
- D4.1. Atika pultovej strechy

Detaily atiky

- D5.1. Atika v spáde 1 - vertikálne uložené panely
- D5.2. Atika v spáde 2 - vertikálne uložené panely

Detail žlábu

- D6.1. Zaatikový žlab (PUR) - s hydrofóliou
- D6.2. Zaatikový žlab (min. vlna) - s hydrofóliou
- D7.1. Pododkvapový žlab (PUR)
- D7.2. Pododkvapový žlab (min. vlna)

- D8.1. Medzistrešný žlab (PUR) - s hydrofóliou
- D8.2. Medzistrešný žlab (min. vlna) - s hydrofóliou

Podhľad

- D9.1. Podhľad

Napojenie stena/strecha

- D10.1. Napojenie stena/strecha 1 - čelné
- D10.2. Napojenie stena/strecha 2 - čelné
- D11.1. Napojenie stena/strecha 1 - v spáde
- D11.2. Napojenie stena/strecha 2 - v spáde

Napojenie strecha/murivo

- D12.1. Napojenie strecha/murivo - čelné
- D13.1. Napojenie strecha/murivo - v spáde

Strecha - svetlíky

- D14.1. Hrebeňový svetlík - napojenie v spáde
- D14.2. Hrebeňový svetlík - čelné napojenie
- D15.1. Bodový svetlík so zatepleným nástavcom

Prestup potrubia - pryžová manžeta

- D16.1. Prestup potrubia - pryžová manžeta

Detaily rohov

- D17.1. Nárožie
- D18.1. Kút

Sokel

- D19.1. Sokel 1
- D19.2. Sokel 2
- D19.3. Sokel 3 (horizontálne panely)
- D19.4. Sokel 4 (horizontálne panely)

Spájanie panelov

- D20.1. Spájanie panelov 1 - vertikálne
- D20.2. Spájanie panelov 2 - vertikálne
- D20.3. Spájanie panelov 3 - horizontálne
- D20.4. Spájanie panelov 4 - horizontálne/vertikálne

Okno

- D21.1. Nadpražie
- D22.1. Parapet 1
- D22.2. Parapet 2
- D23.1. Ostenie

Ukončenie steny

- D24.1. Ukončenie steny 1
- D24.2. Ukončenie steny 2

Rolovacie dvere

- D25.1. Nadpražie
- D26.1. Ostenie

Uchytenie priečok

- D27.1. Uchytenie priečok pri strope
- D28.1. Uchytenie priečok pri podlahe 1
- D28.2. Uchytenie priečok pri podlahe 2

Spoj strešného a presvetľovacieho panela

- D29.1. v spáde
- D29.2. čelný

Spoj stenového a presvetľovacieho panela

- D30.1. nadpražie
- D30.2. parapet
- D30.3. ostenie

D1.1. - HREBEŇ

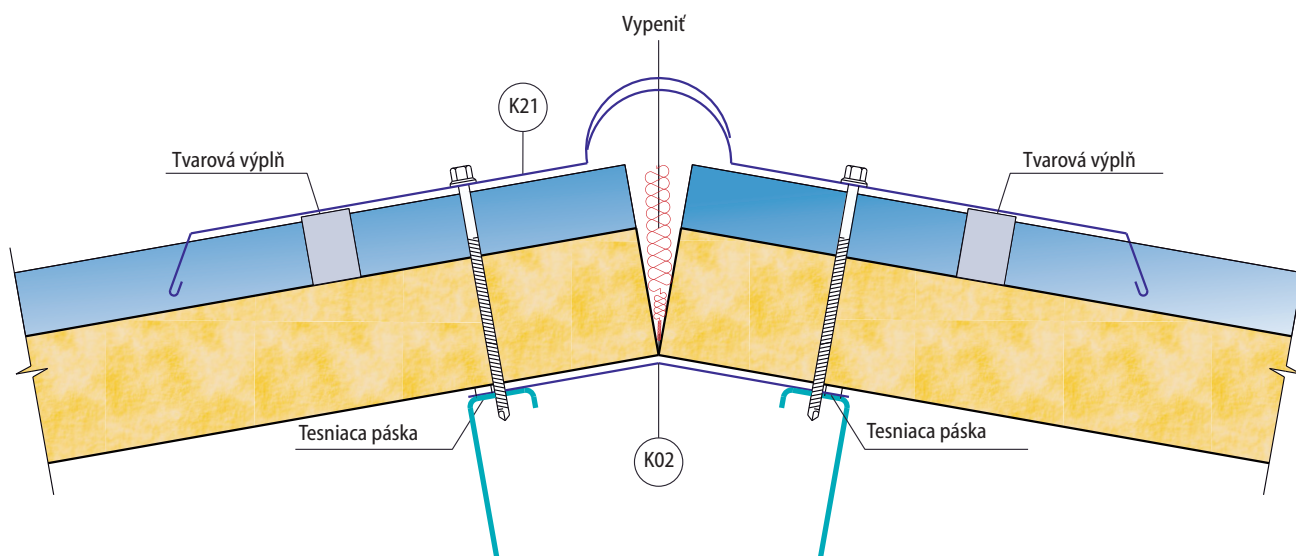

D1.2. - HREBEŇ

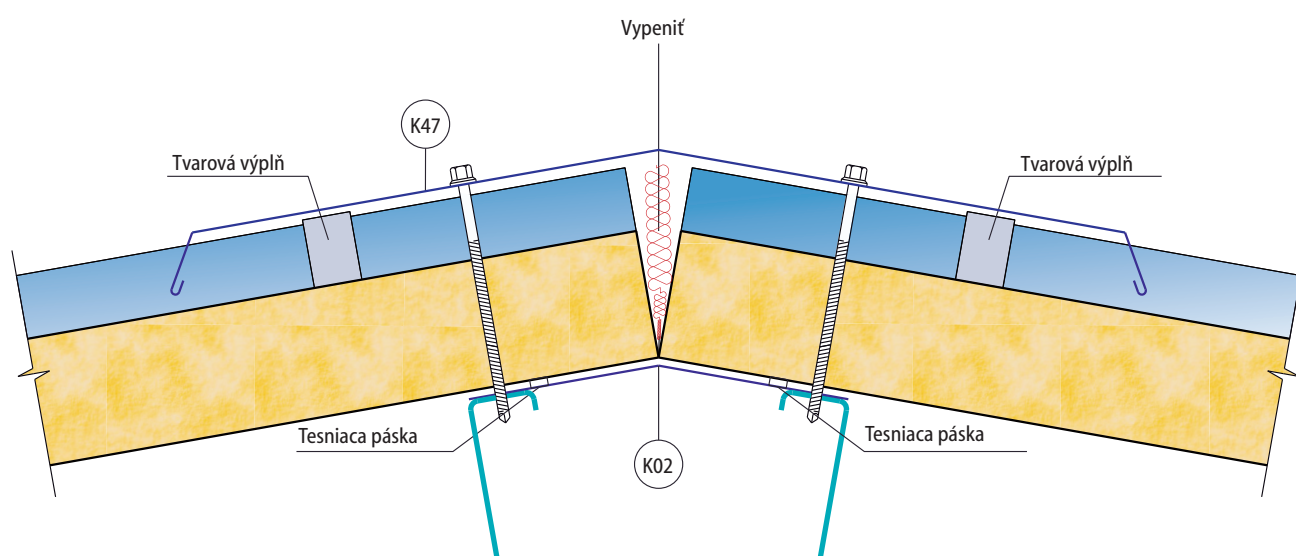

D2.1. - ŠTÍT

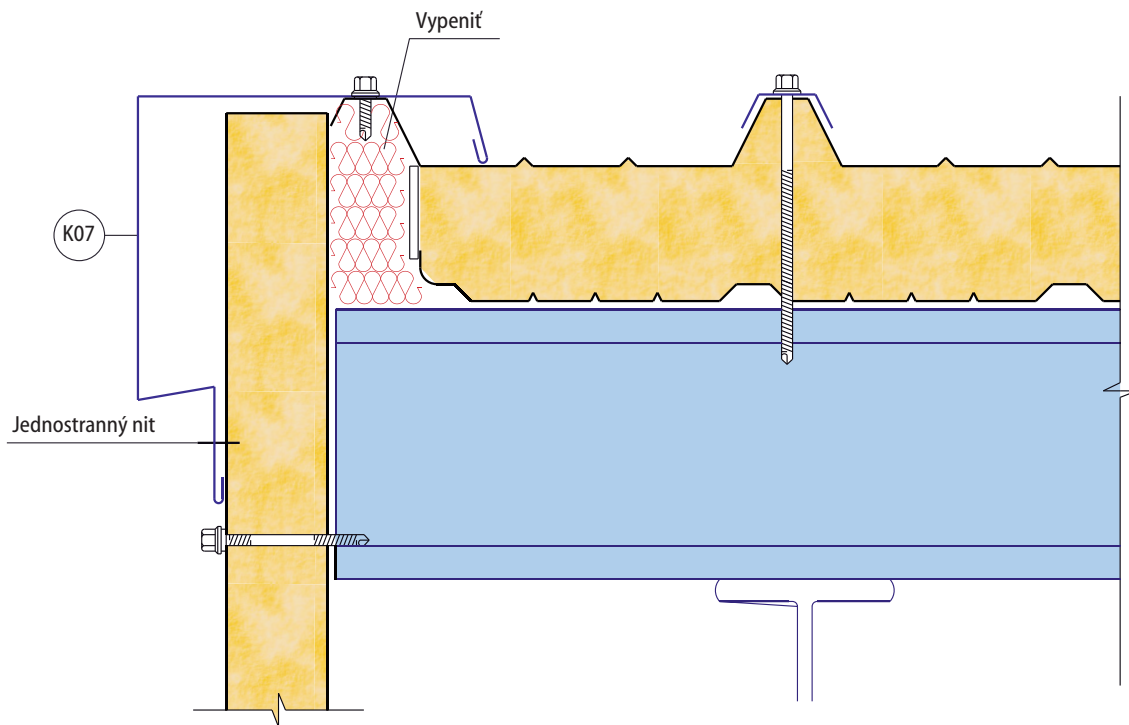

D2.2. - ŠTÍT

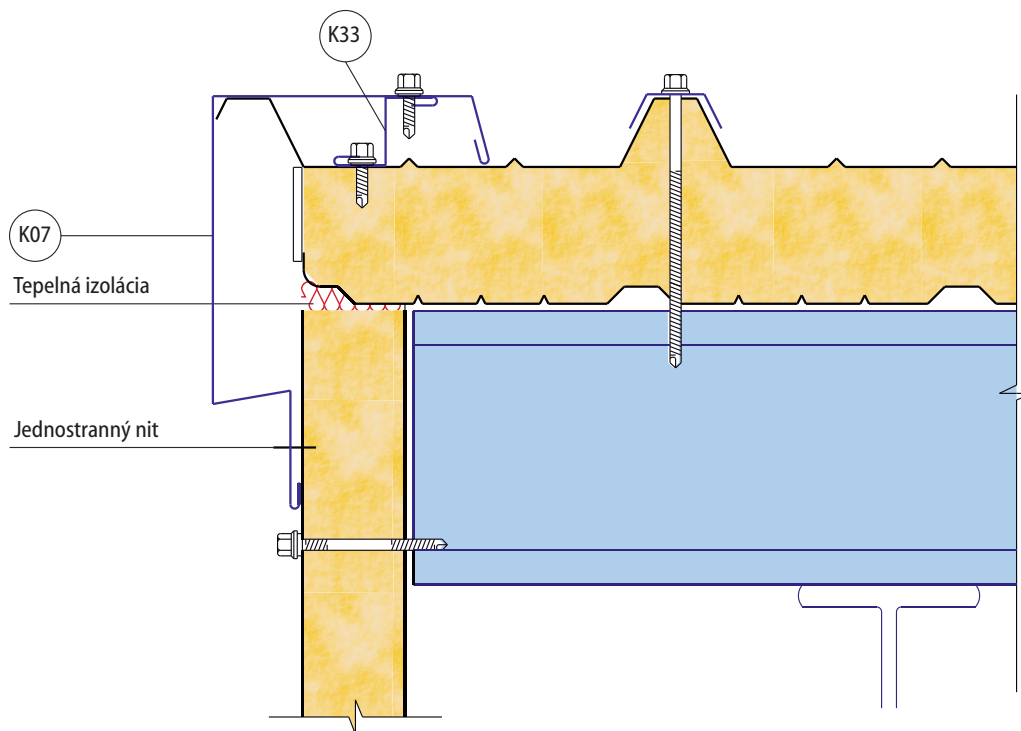

D2.3. - ŠTÍT s presahom

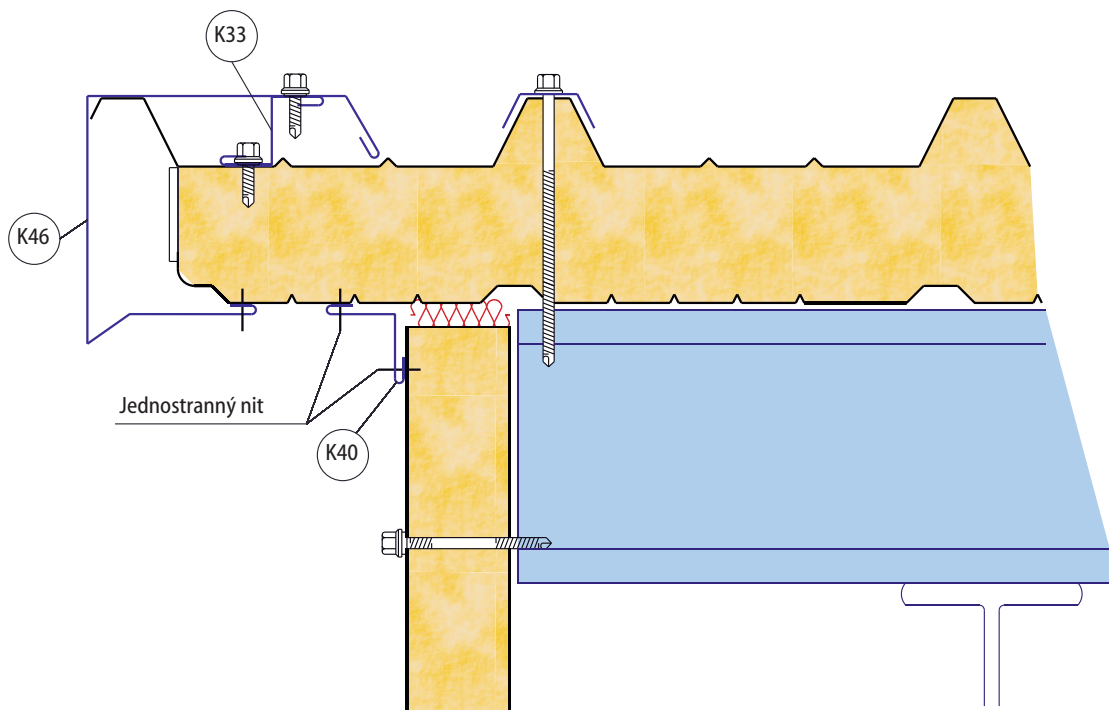

D3.1. - PULT

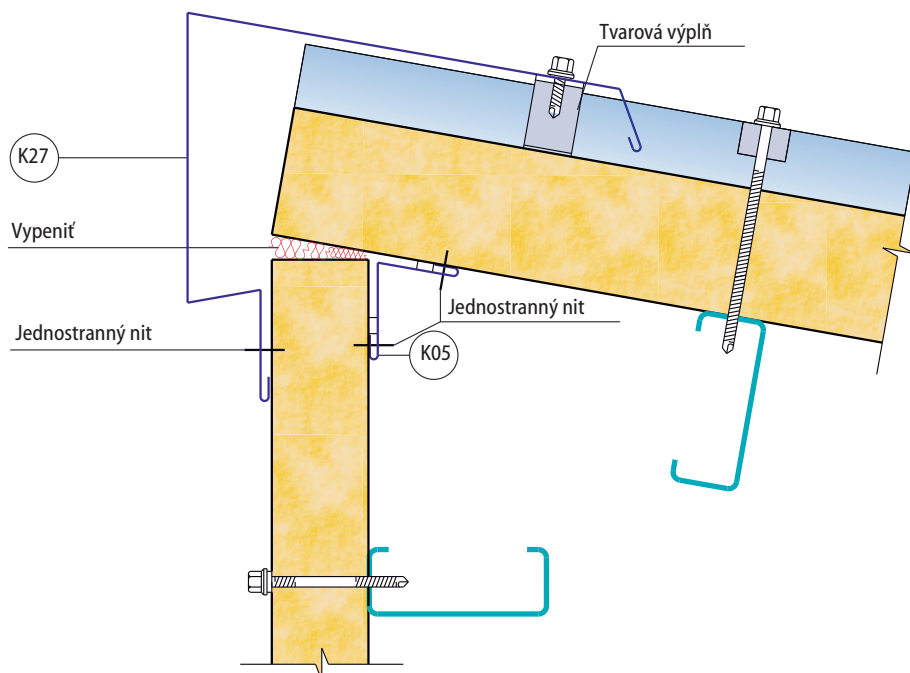

D4.1. ATIKA PULTOVEJ STRECHY

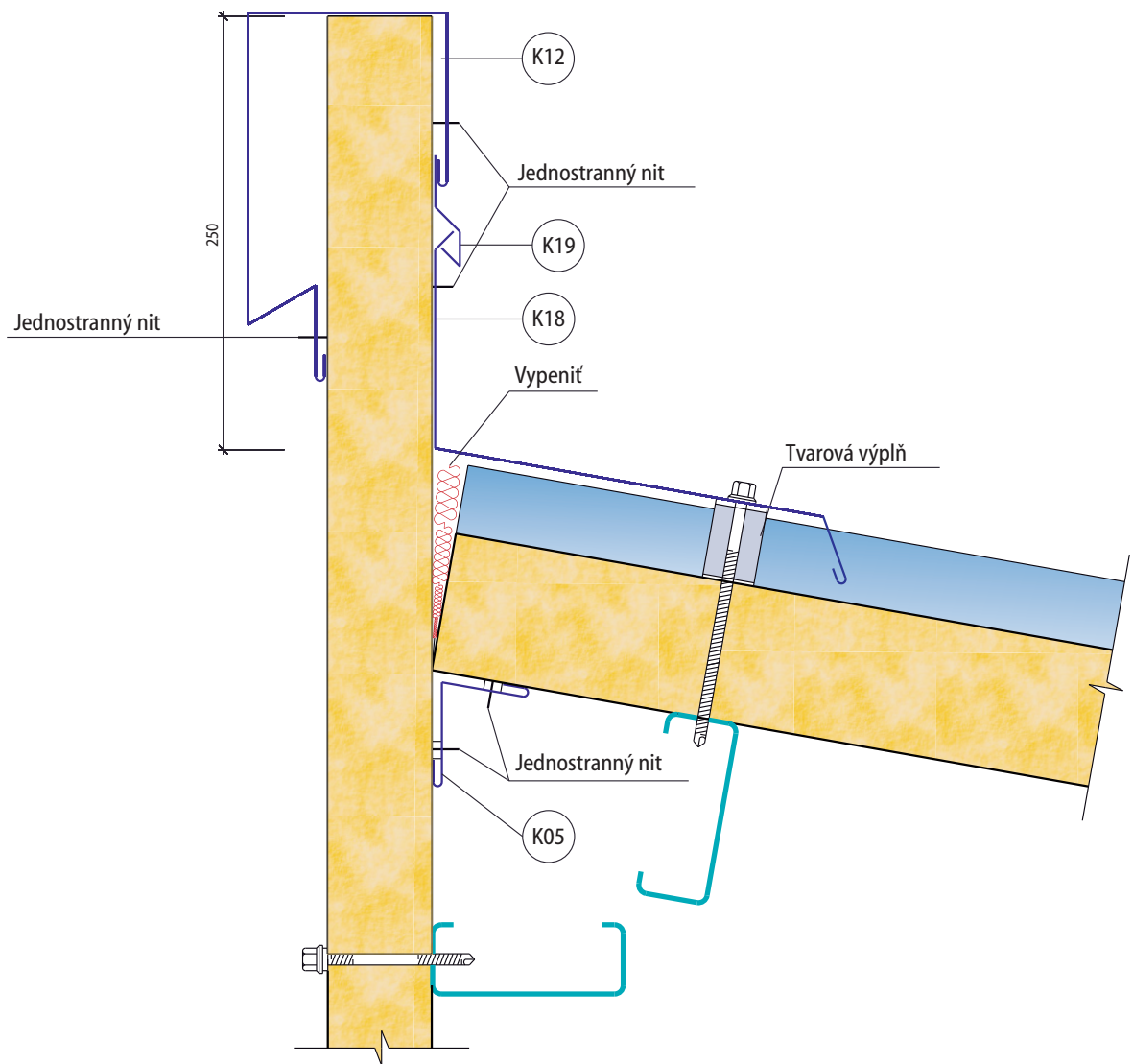

D5.1. - ATIKA V SPÁDE - vertikálne uložené panely

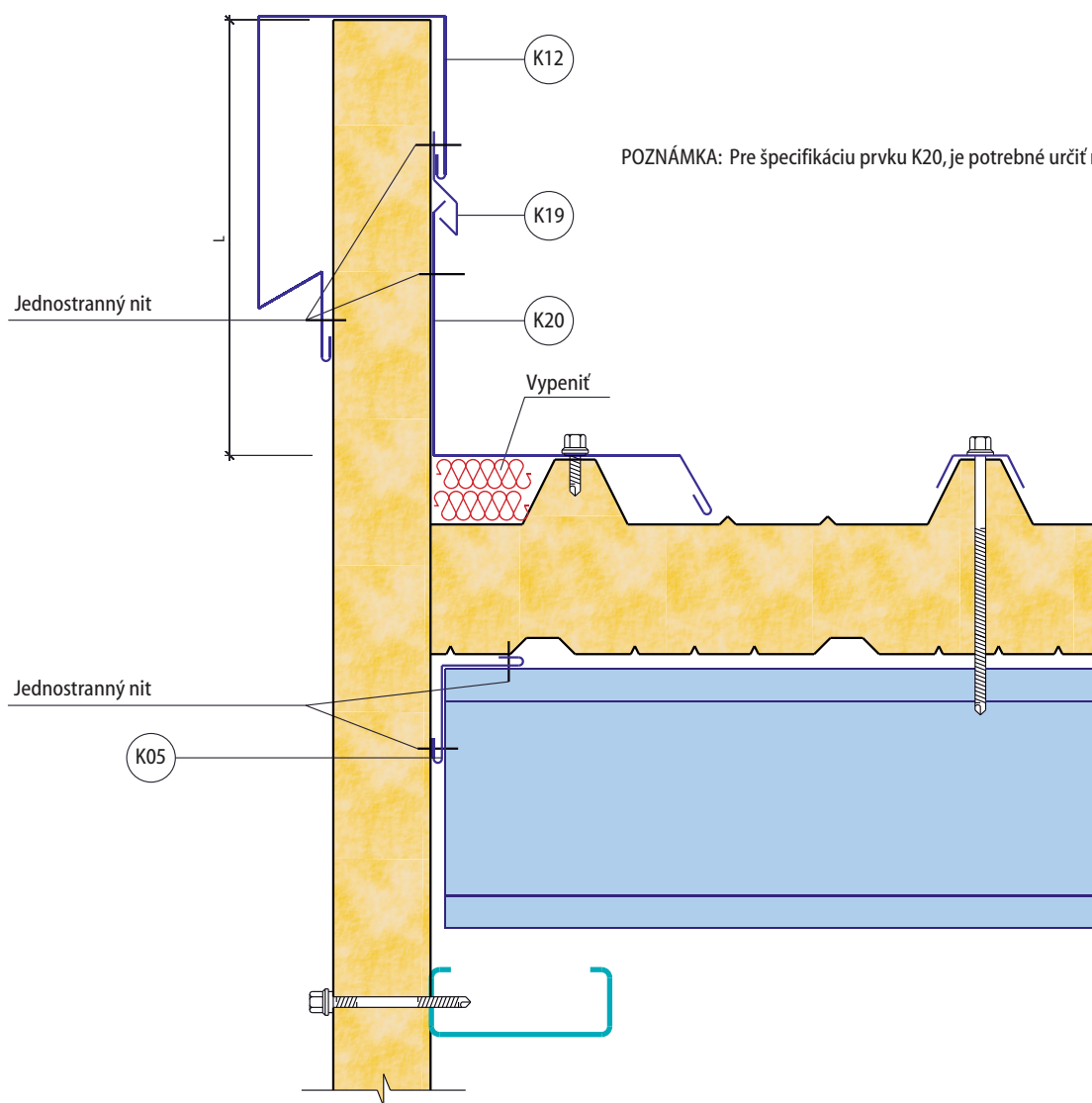

D5.2. - ATIKA V SPÁDE - vertikálne uložené panely

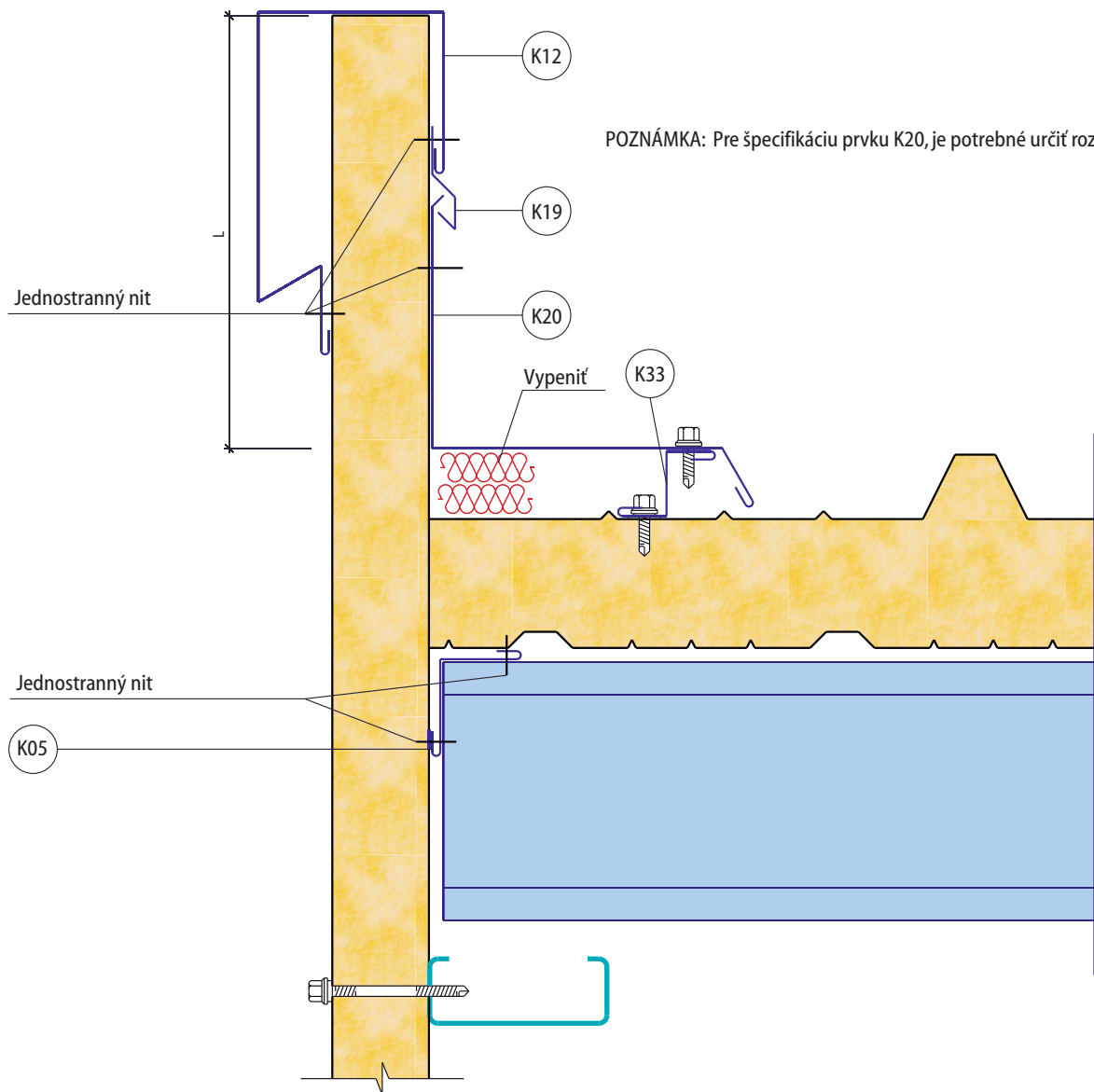

D6.1. - ZAATIKOVÝ ŽĽAB - s hydrofóliou pre panely s izoláciou PUR

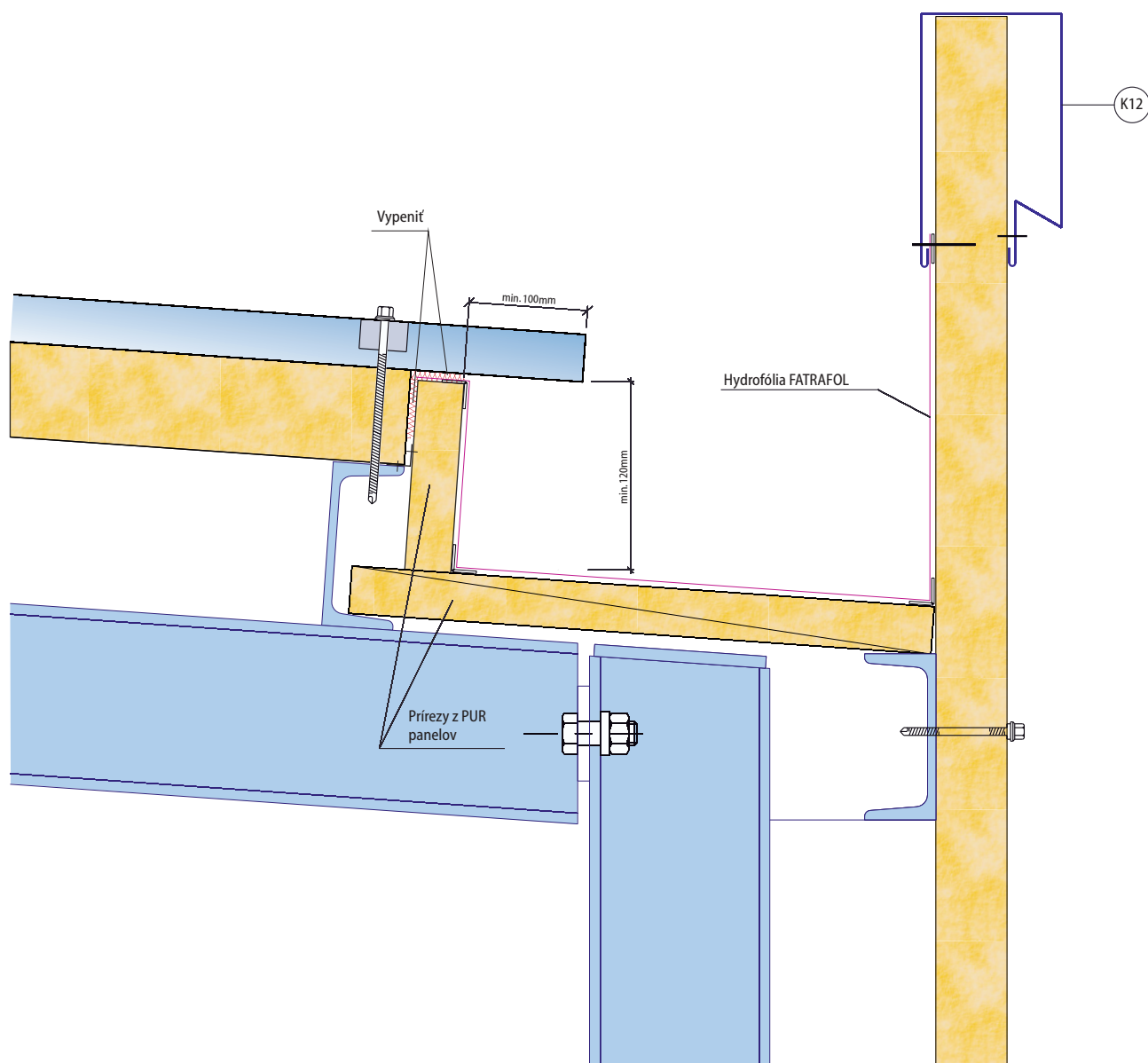

**D6.2. - ZAATIKOVÝ ŽLAB - s hydrofóliou
pre panely s izoláciou z minerálnej vlny**

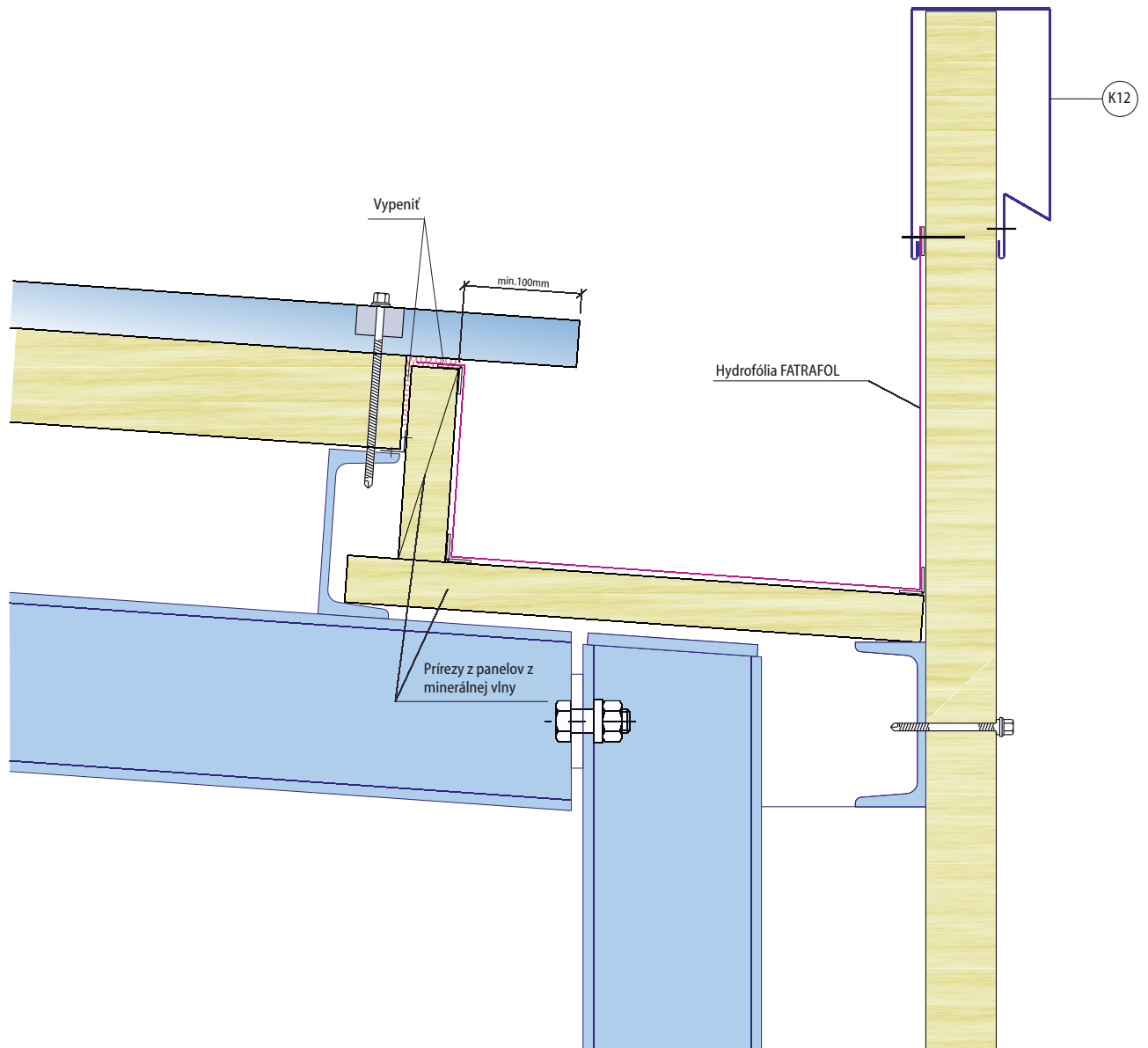

D7.1. - PODODKVAPOVÝ ŽĽAB - pre panely s izoláciou PUR

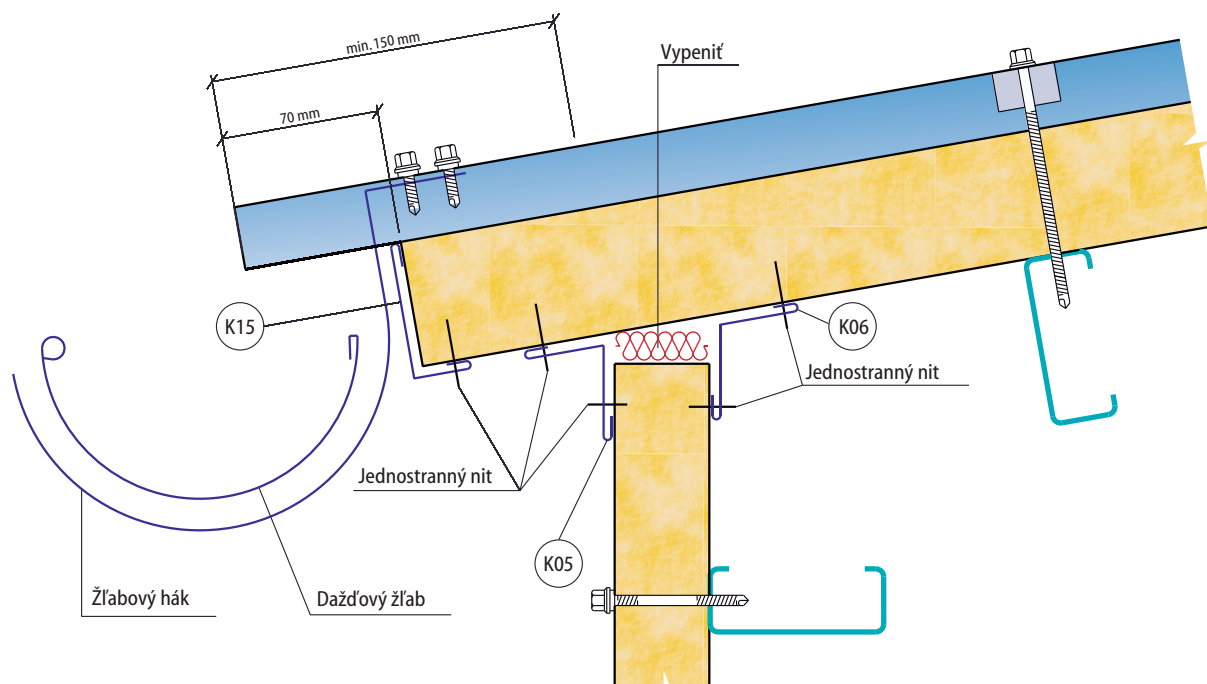

D7.2. - PODODKVAPOVÝ ŽĽAB - pre panely s izoláciou z minerálnej vlny

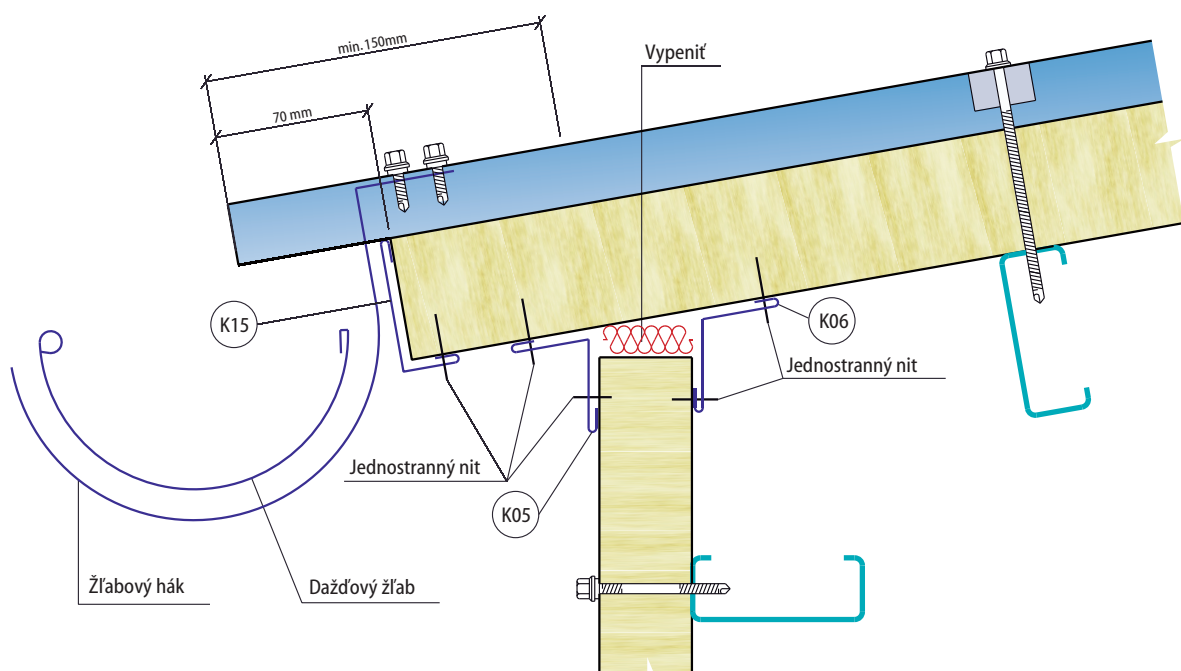

D8.1. - MEDZISTREŠNÝ ŽLAB - pre panely s izoláciou PUR

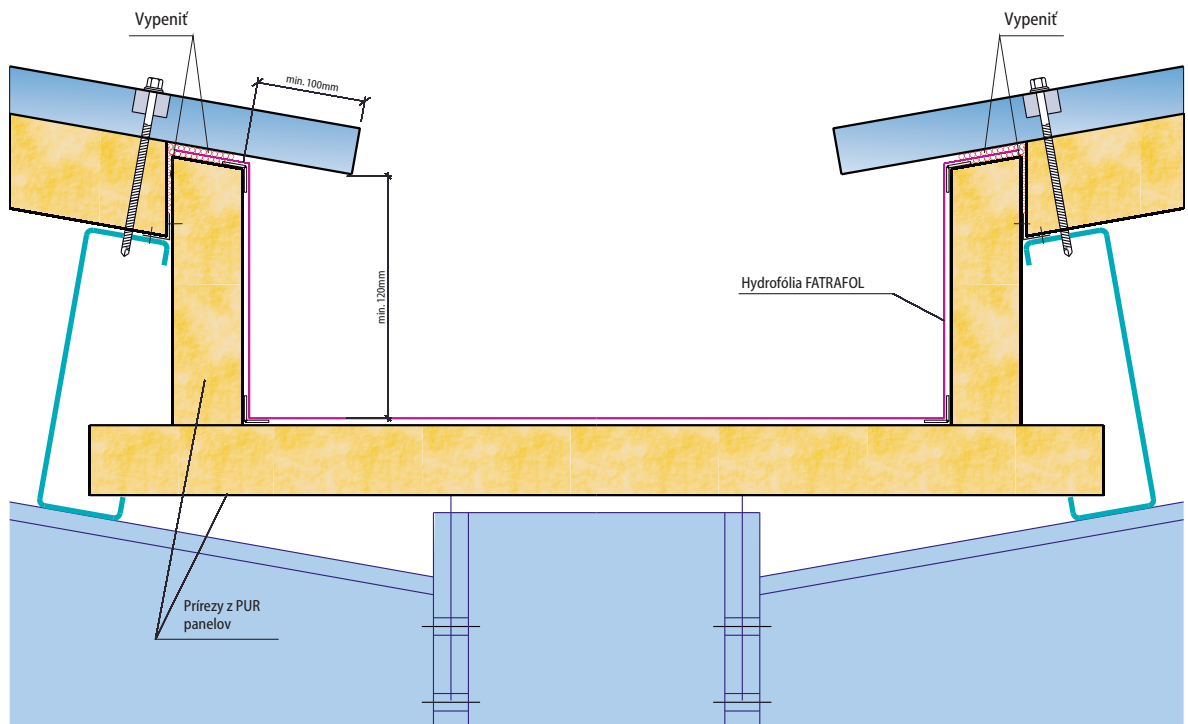

D8.2. - MEDZISTREŠNÝ ŽLAB - pre panely s izoláciou z minerálnej vlny

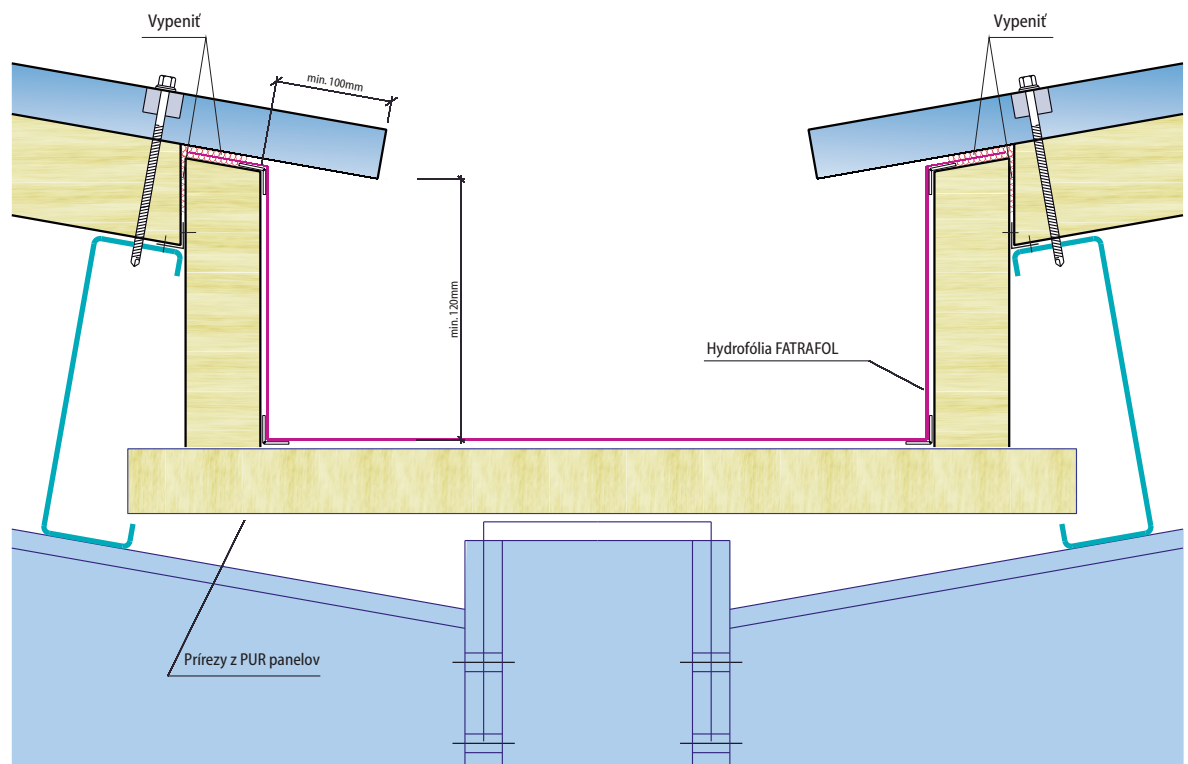

D9.1. PODHLAD

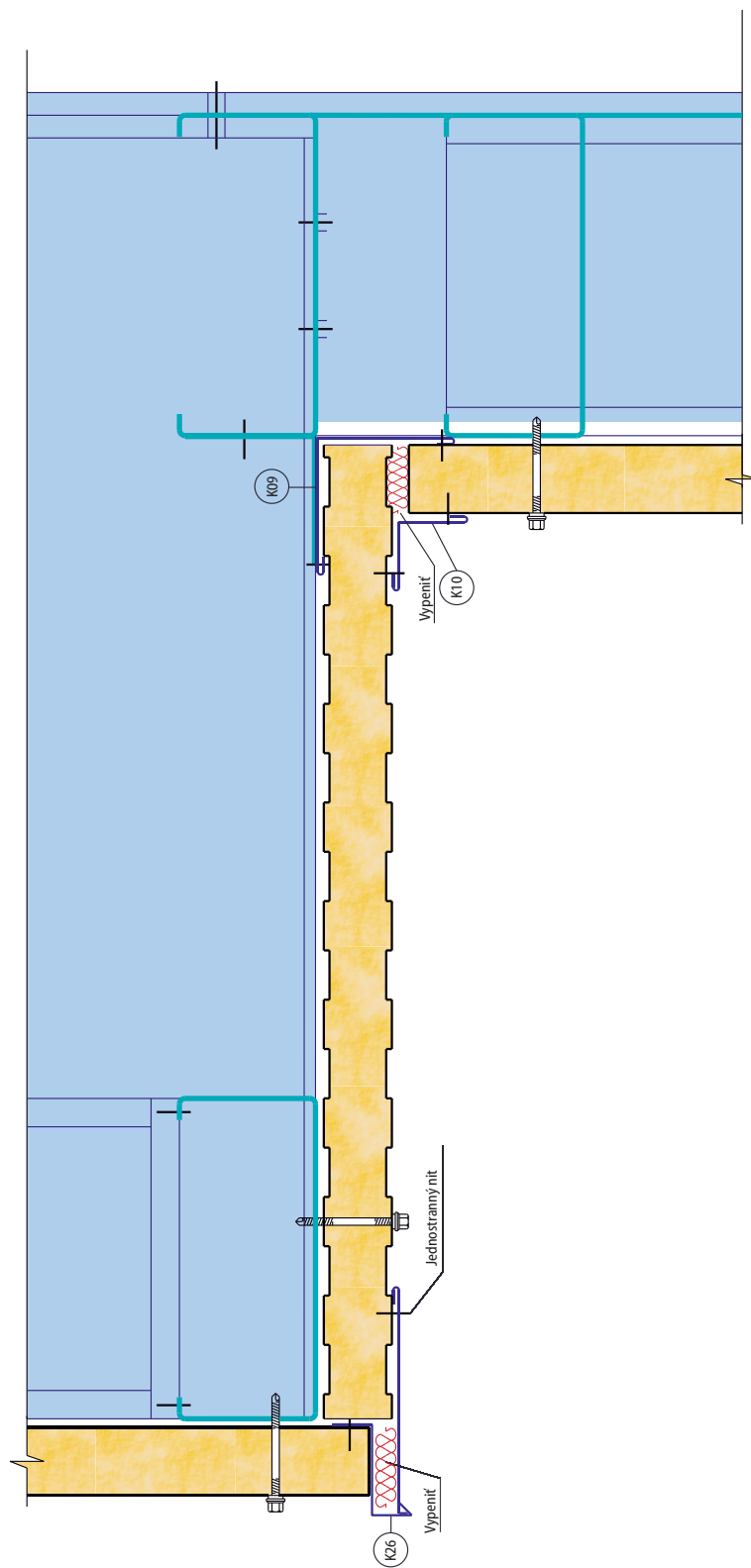

D10.1. - NAPOJENIE STENA/STRECHA - čelné

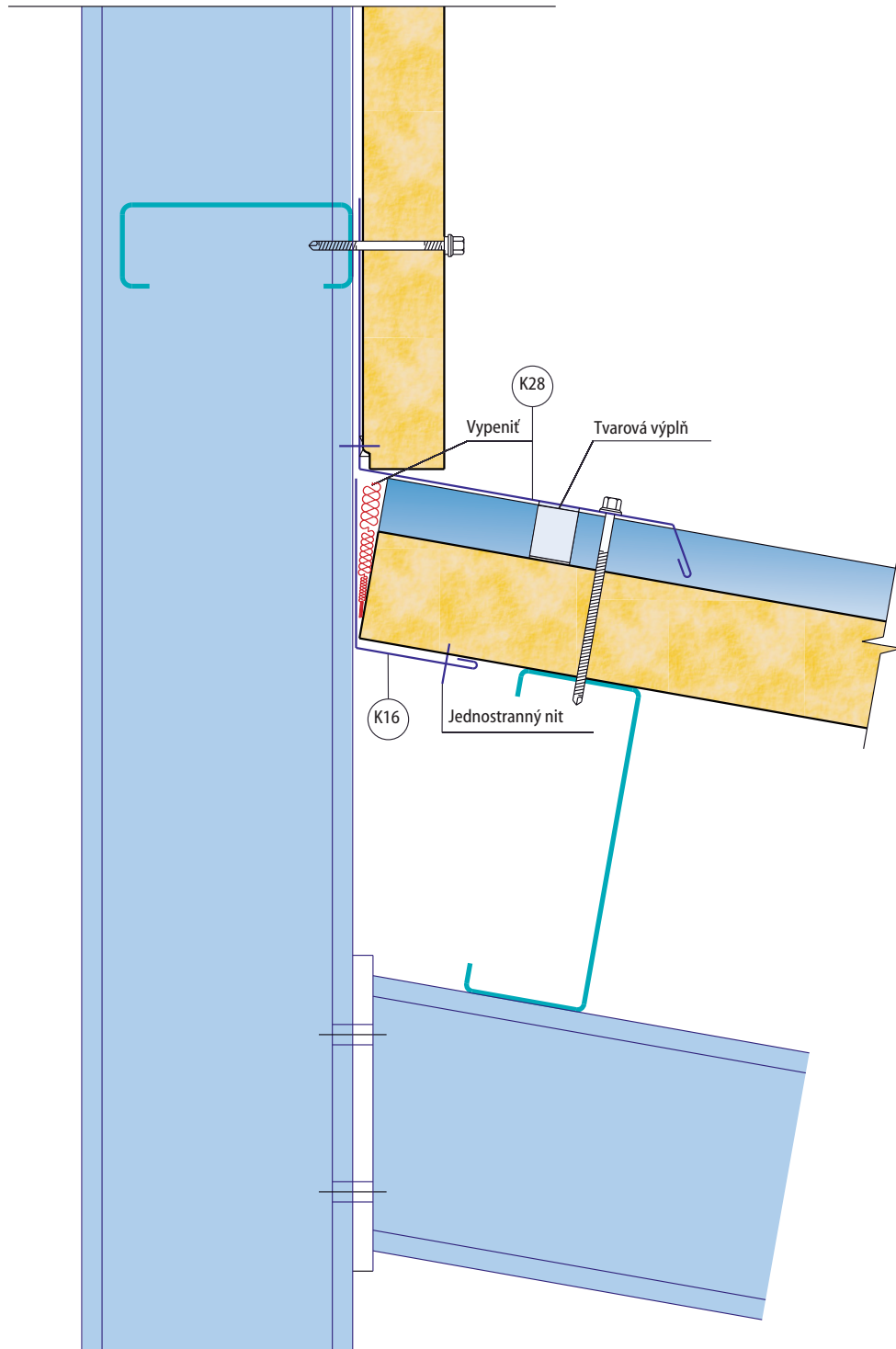

D10.2. - NAPOJENIE STENA/STRECHA - čelné

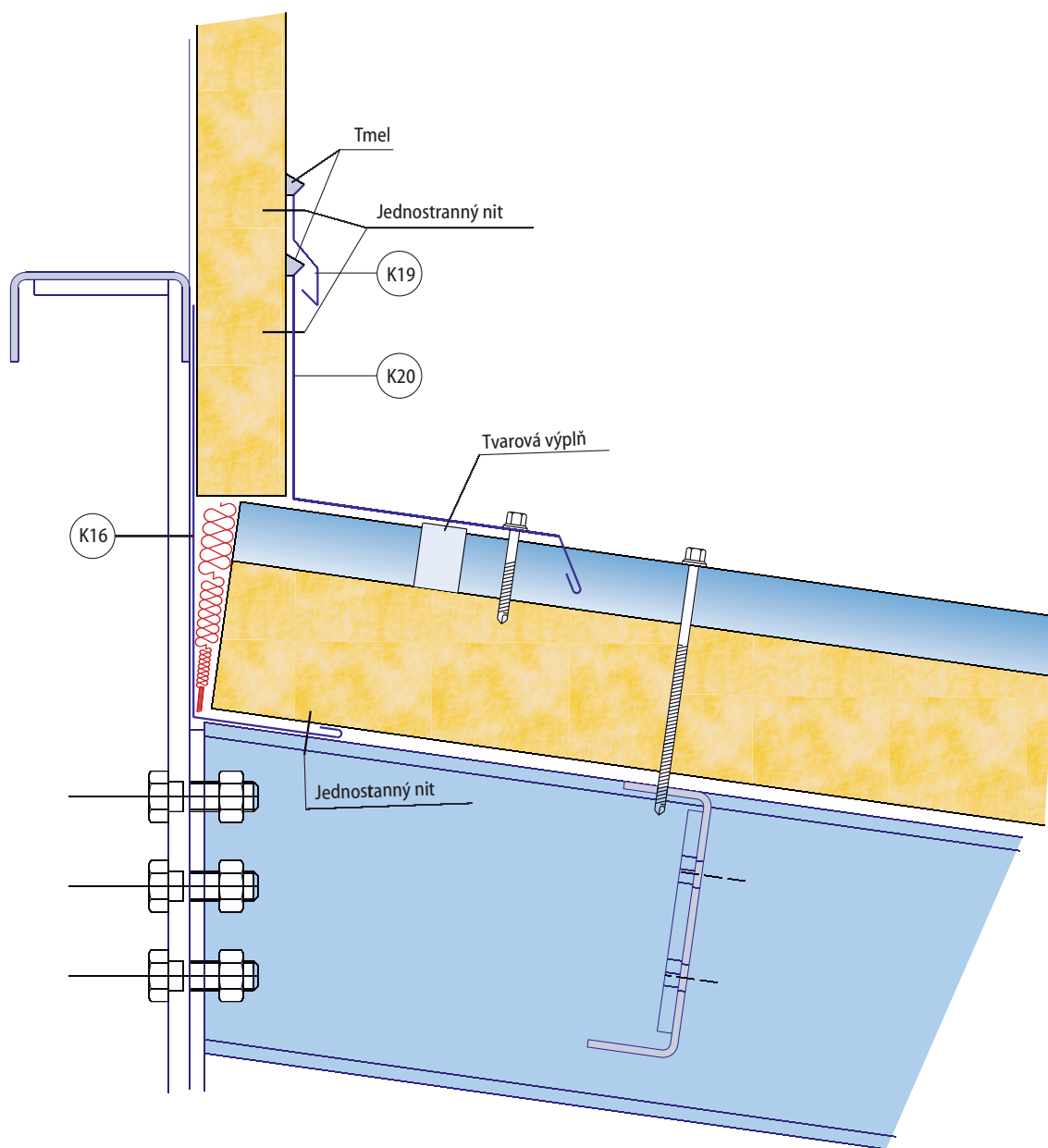

D11.1. - NAPOJENIE STENA/STRECHA - v spáde

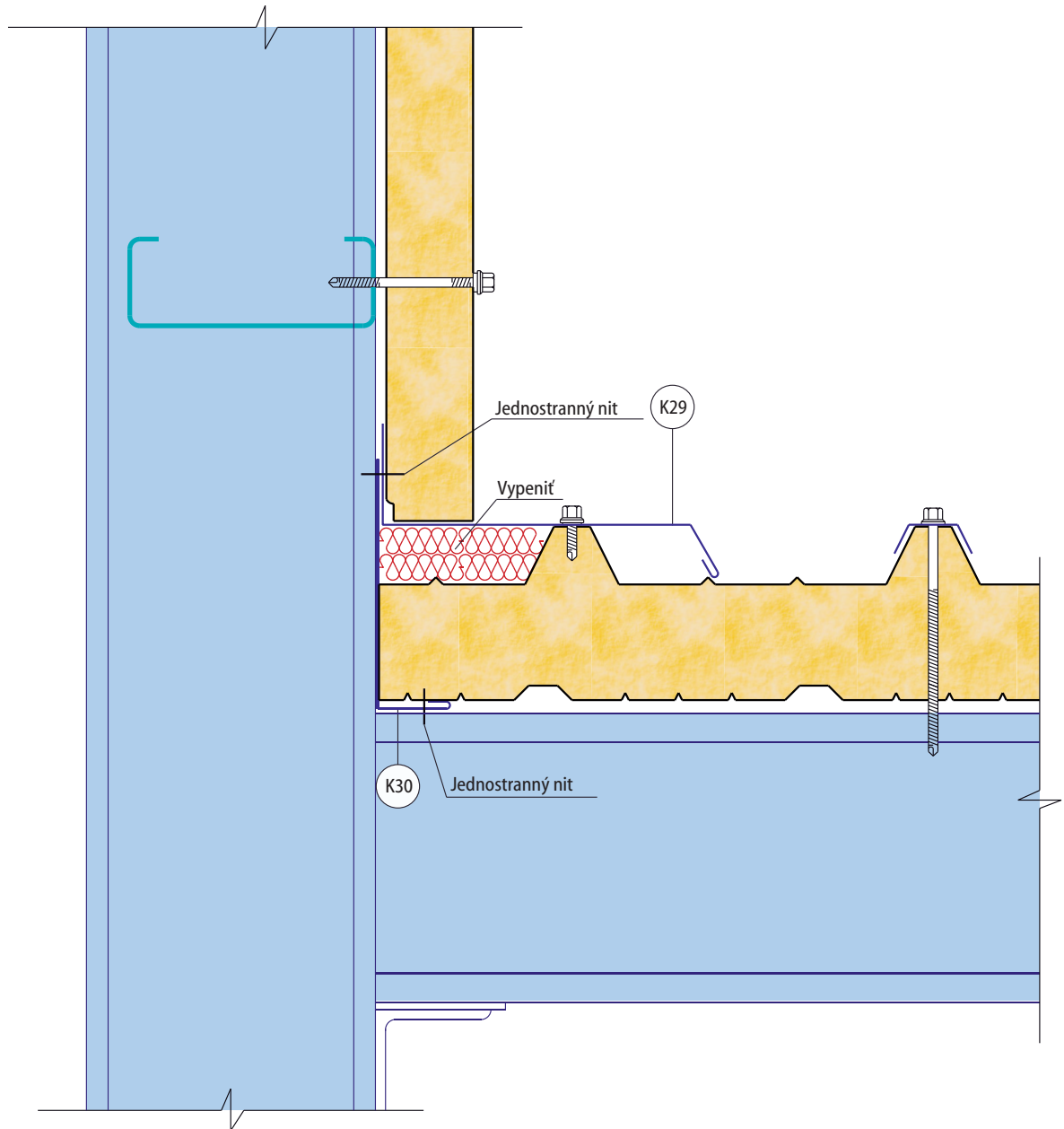

D11.2. - NAPOJENIE STENA/STRECHA - v spáde

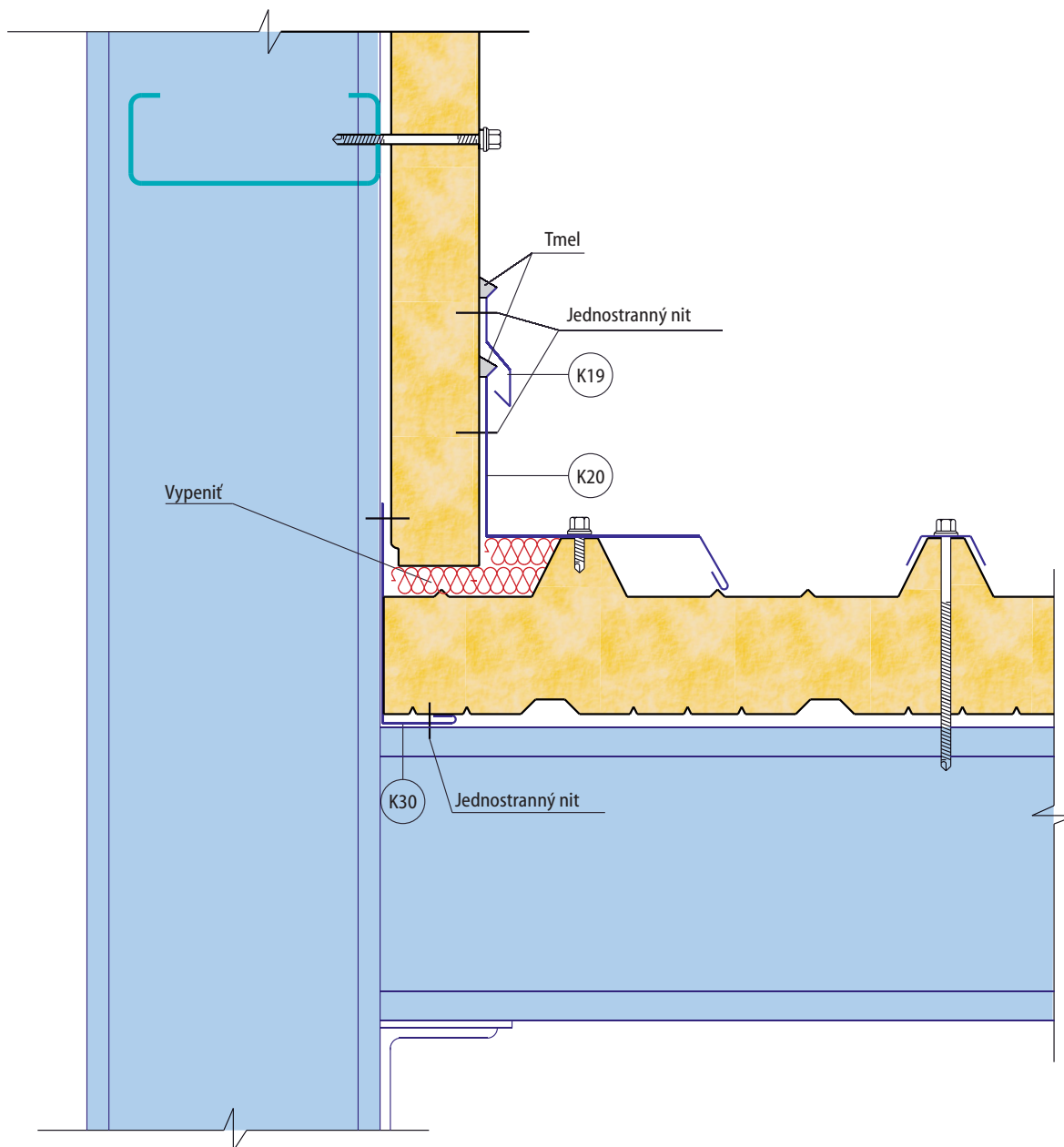

D12.1. NAPOJENIE STRECHA/MURIVO - čelné

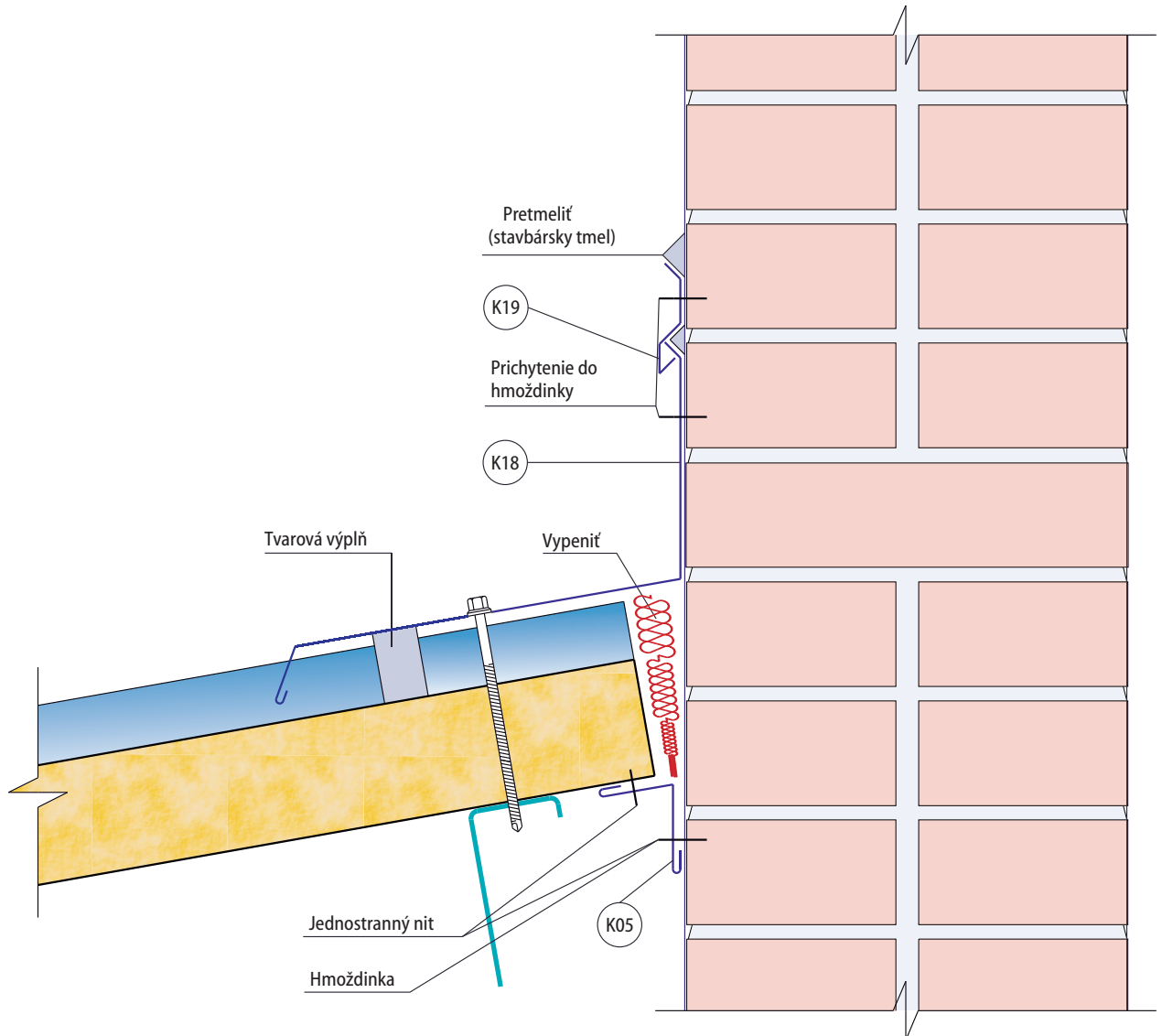

D13.1. NAPOJENIE STRECHA/MURIVO - v spáde

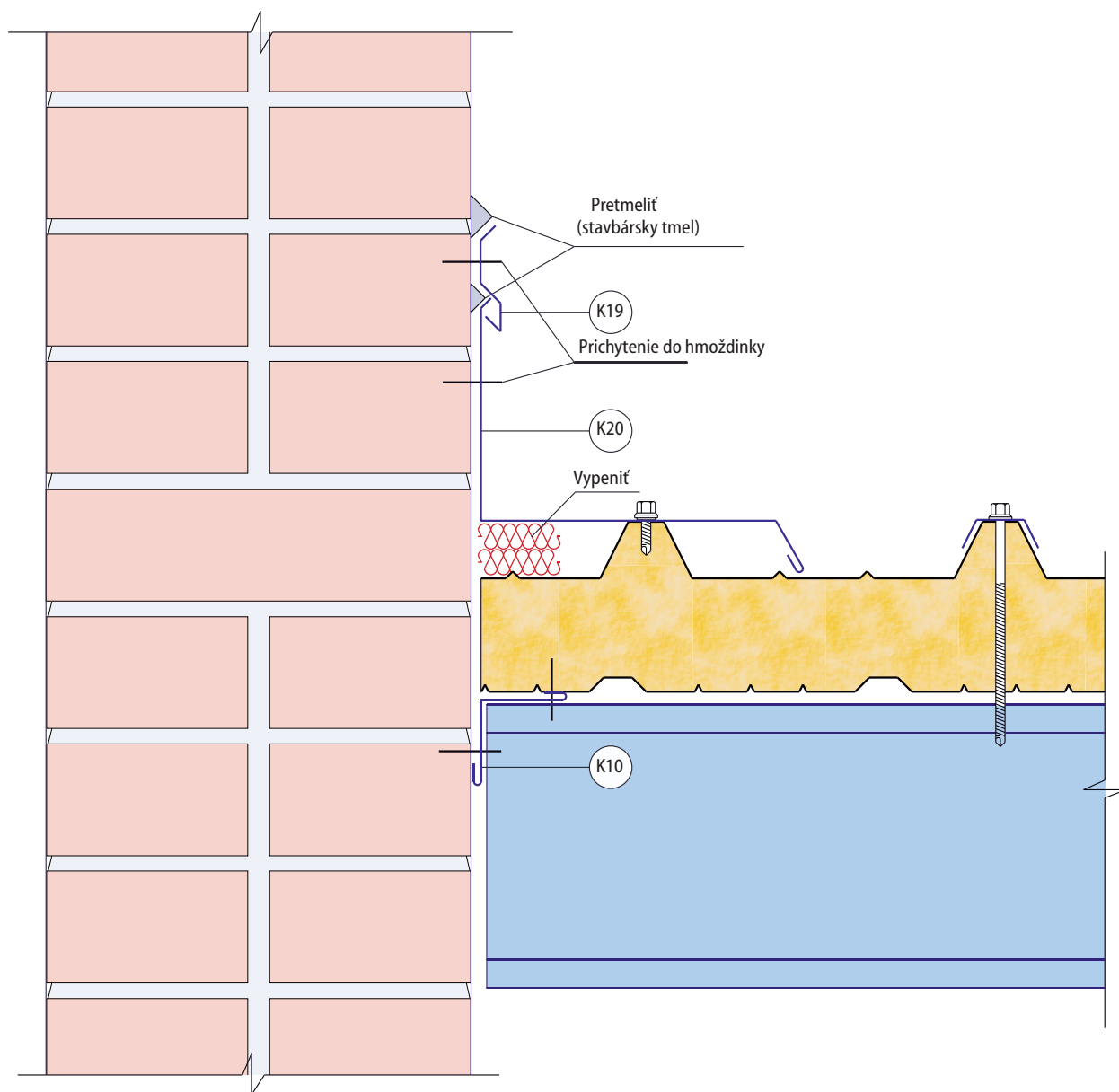

D14.1. HREBEŇOVÝ SVETLÍK - napojenie v spáde

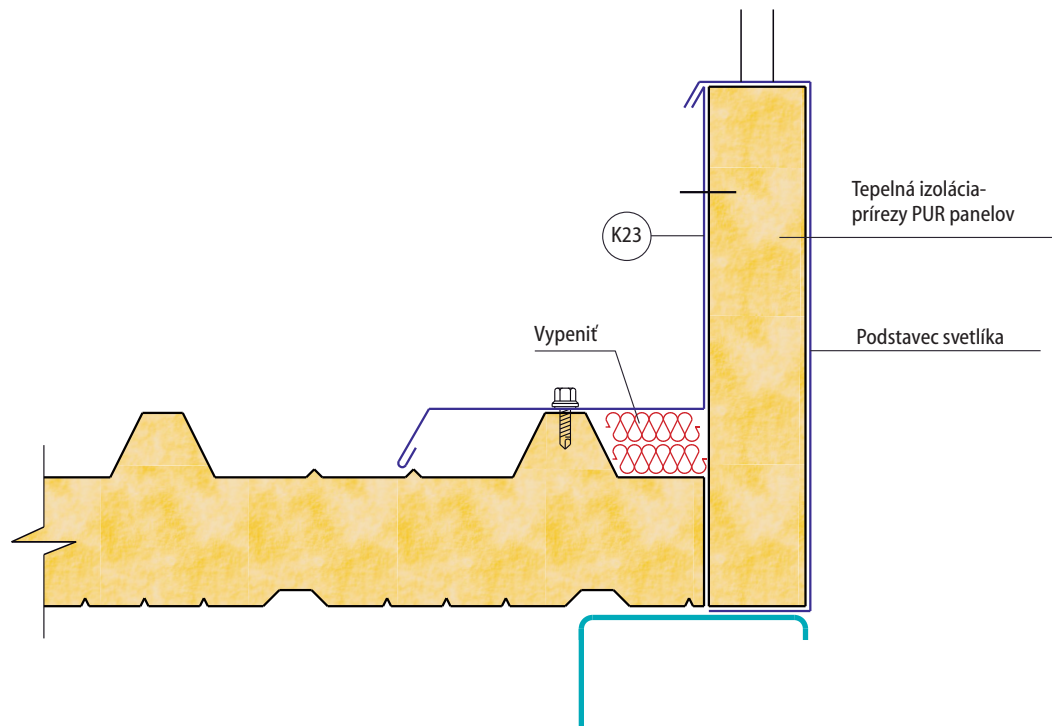

D14.2. HREBEŇOVÝ SVETLÍK - čelné napojenie

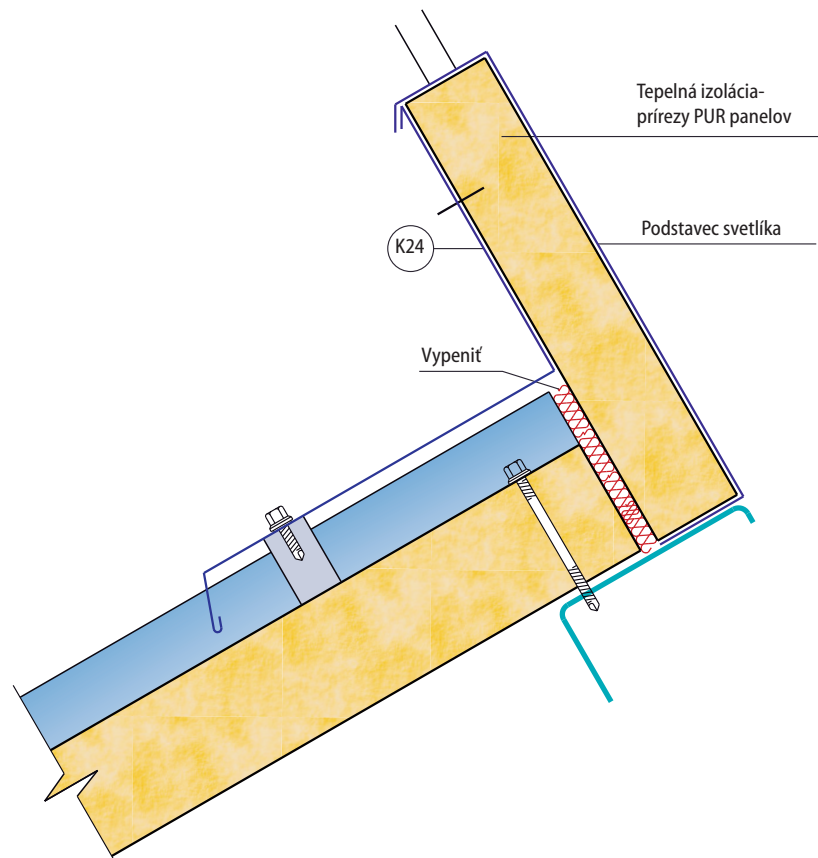

D15.1. BODOVÝ SVETLÍK SO ZATEPLENÝM NÁDSTAVCOM

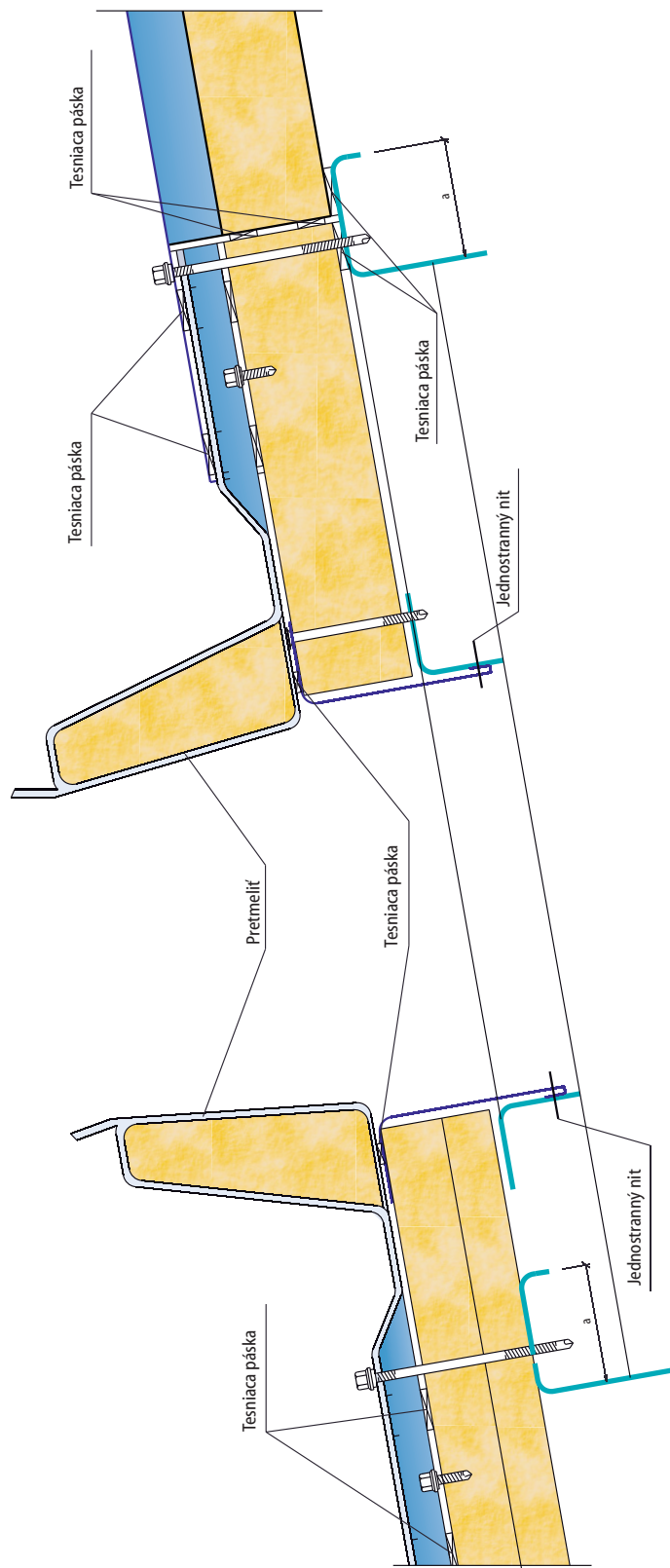

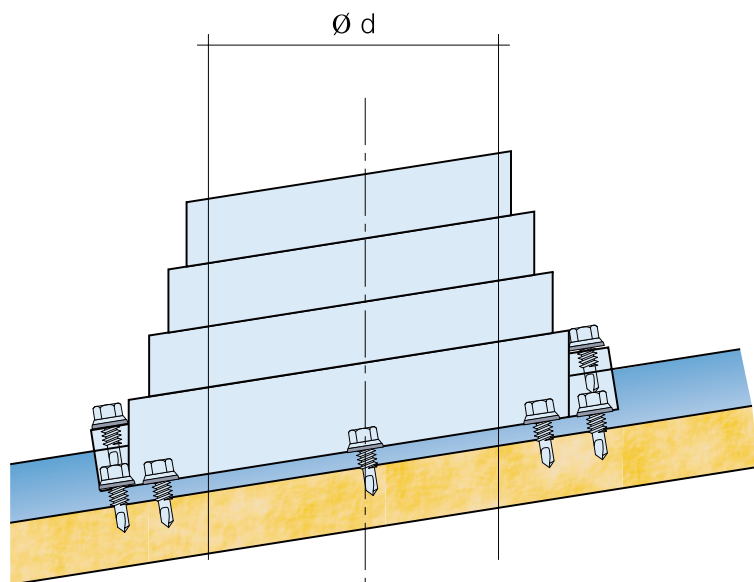
D.16.1. PRESTUP POTRUBIA - pryžová manžeta

Typ	Užitočný o potrubia /vlna max. 40mm/	Základ podstavy /mm/
CUP min.	3-20	60
CUP 1	6-50	115
CUP 2	30-75	150
CUP 3	6-100	200
CUP 4	75-150	255
CUP 5	100-175	280
CUP 6	125-230	305
CUP 7	150-280	355
CUP 8	175-330	430
CUP 9	245-490	630
CUP max.	305-660	865

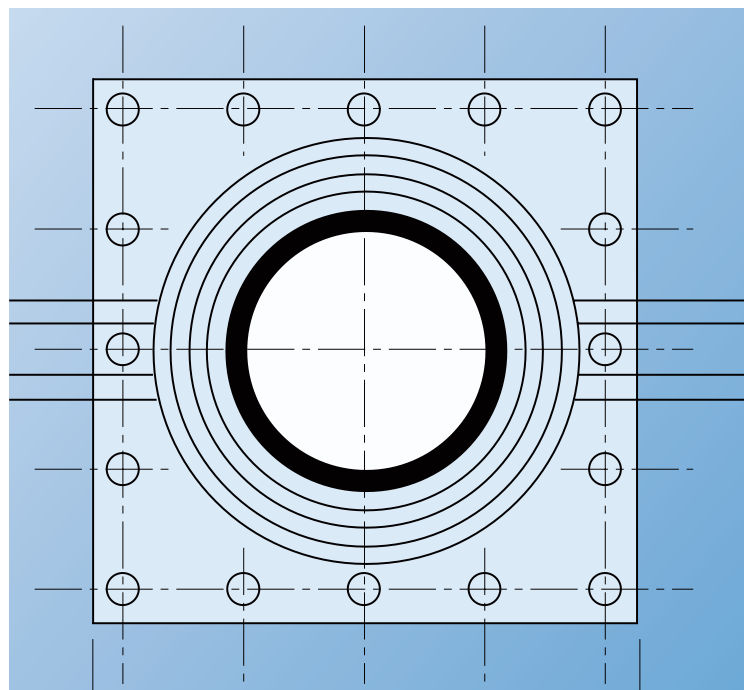

POZNÁMKA:

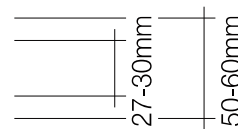
Hadicové objímky pre lepšie dodatočné utesnenie prestupov je treba objednať podľa priemeru potrubia.

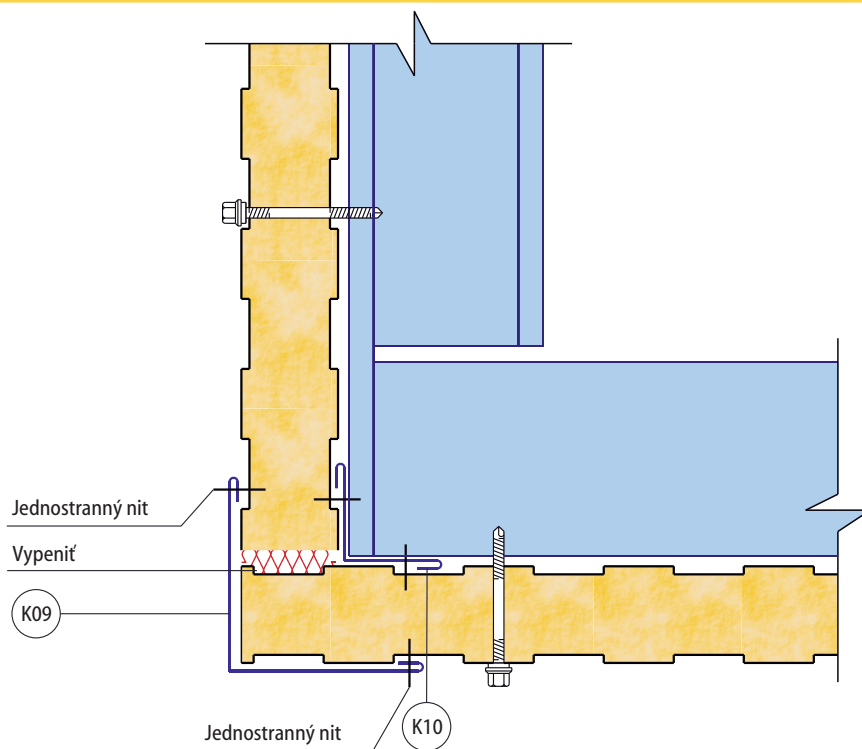

základ podstavy

D17.1. DETAIL ROHU - nárožie



D18.1. DETAIL ROHU - kút

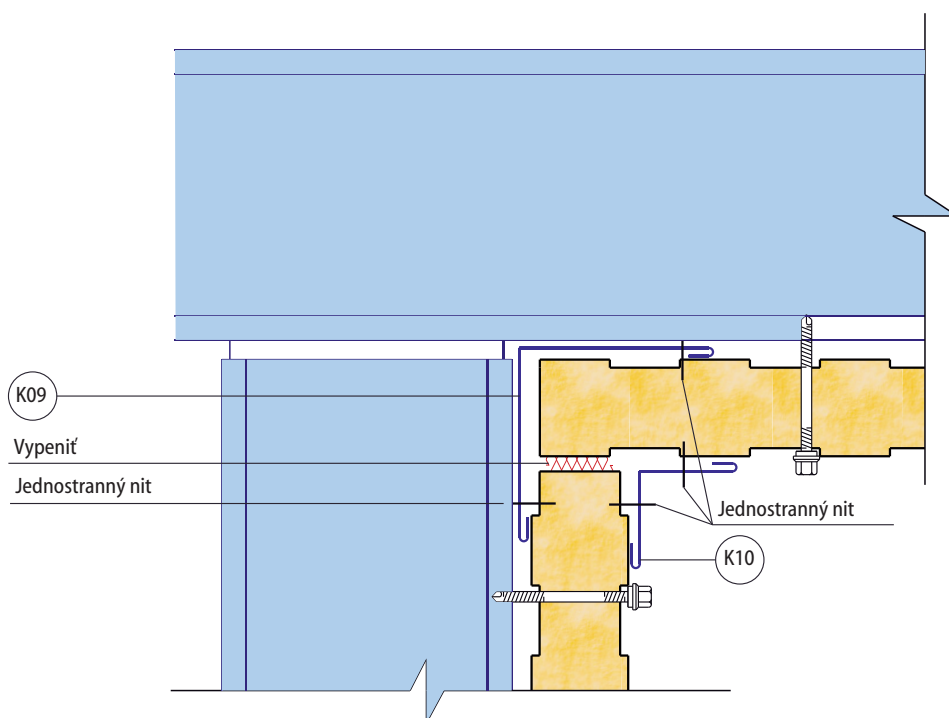

D.19.1. - SOKEL

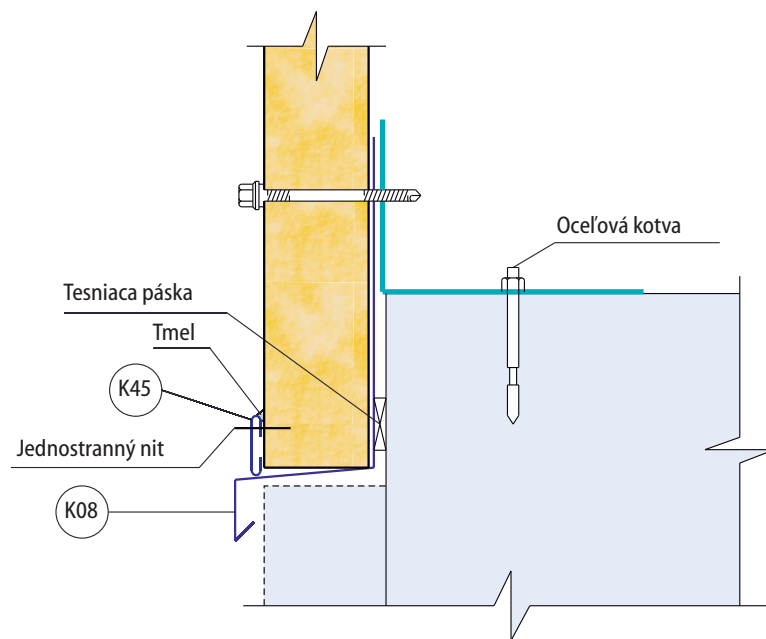

D.19.2. SOKEL

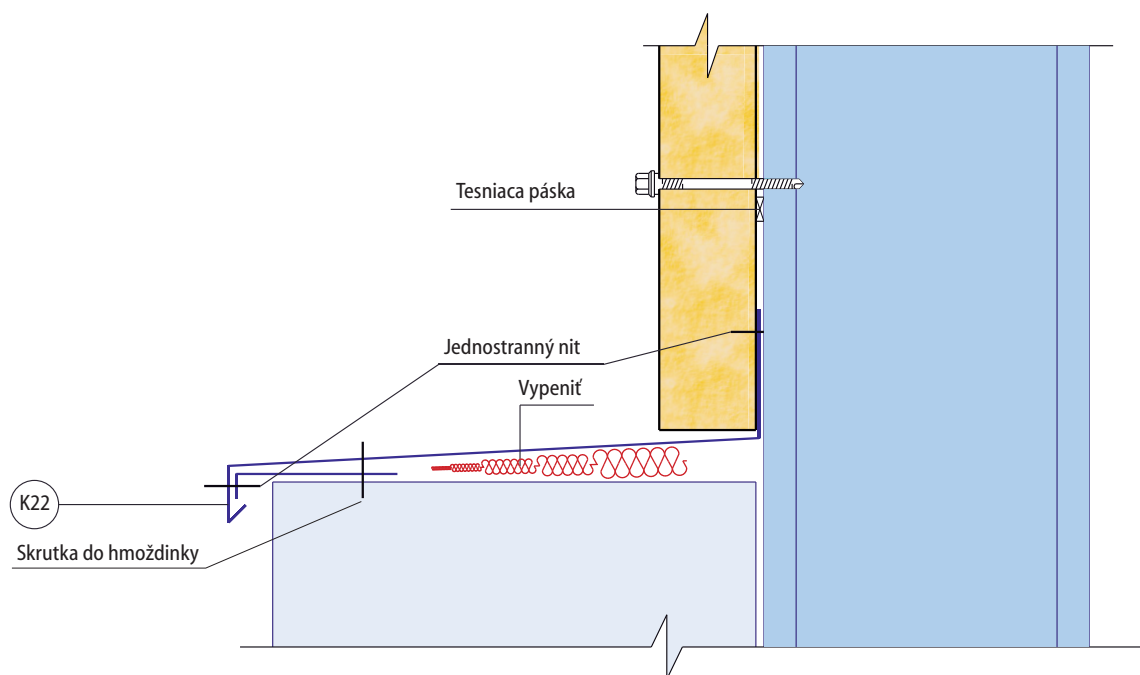

D.19.3. SOKEL - horizontálne panely

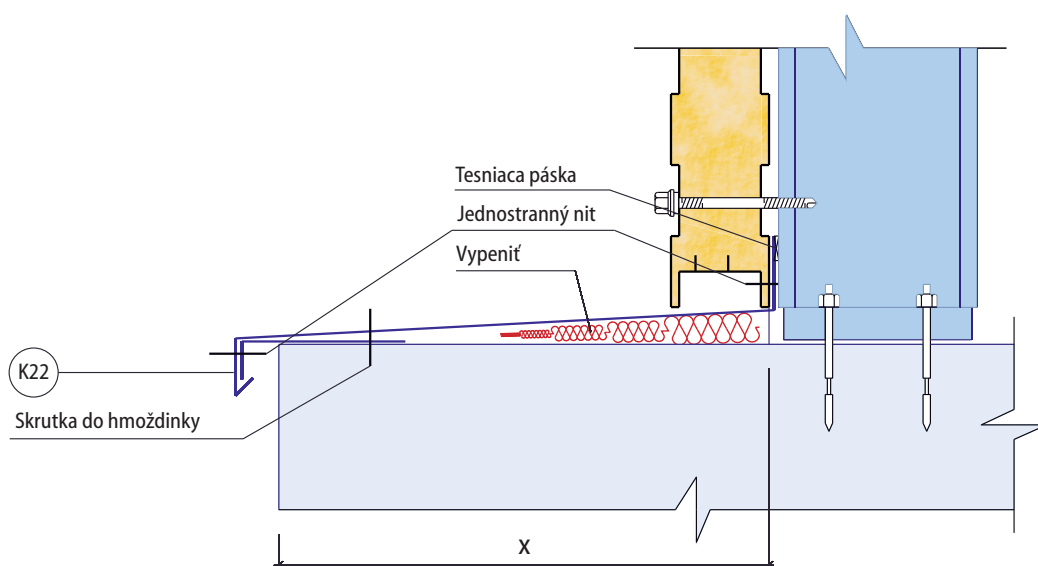

D.19.4. SOKEL - horizontálne panely

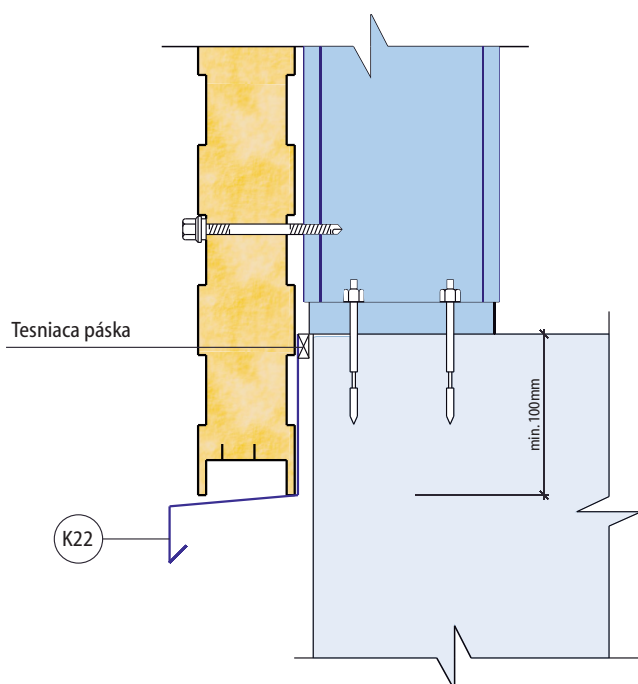

D.20.1. - SPÁJANIE PANELOV - vertikálne

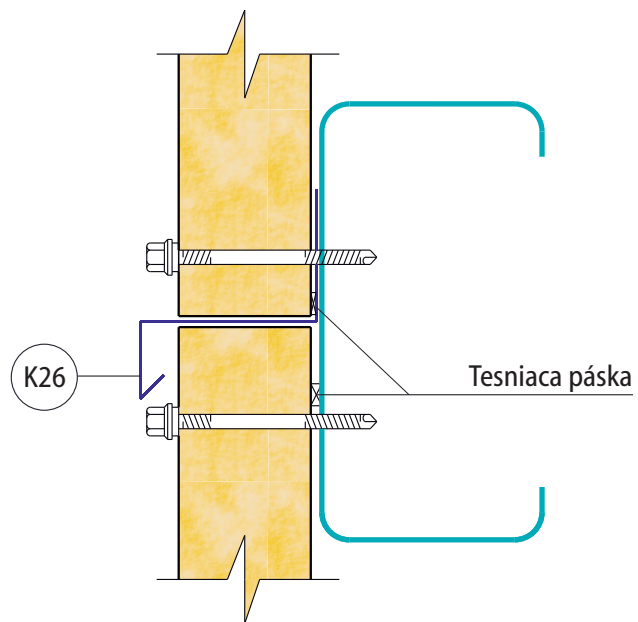

D.20.2. - SPÁJANIE PANELOV - vertikálne

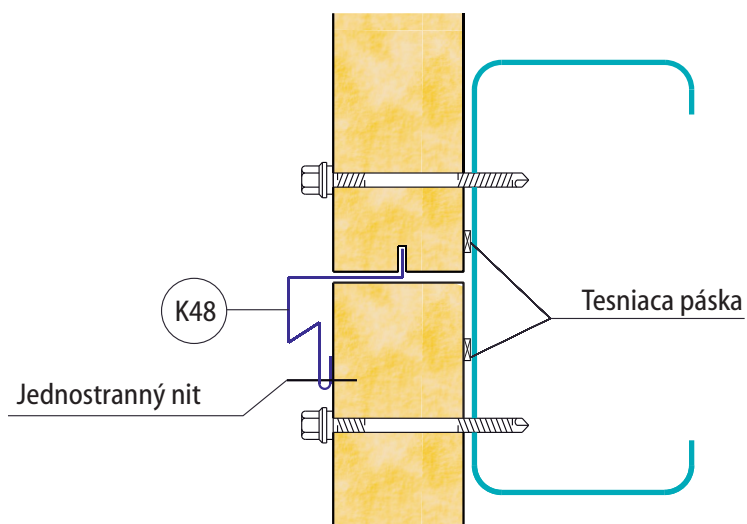

D.20.3. - SPÁJANIE PANELOV - horizontálne

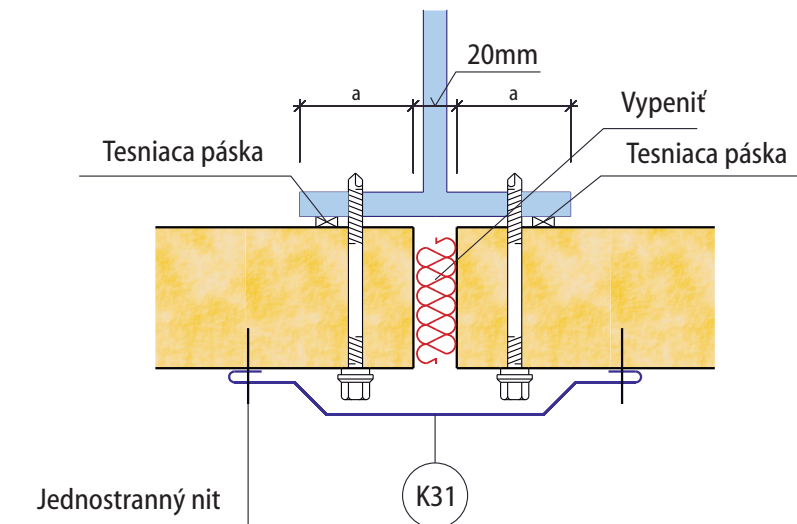

D.20.4. NAPOJENIE PANELU - horizontálny/vertikálny

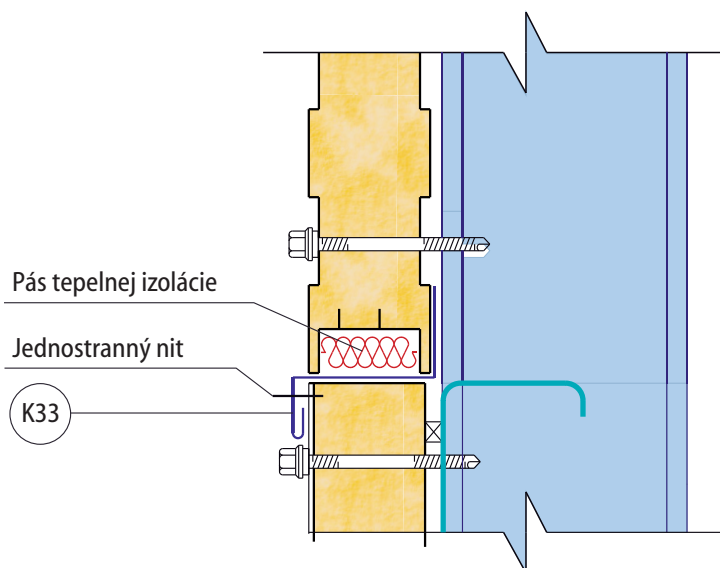

D.21.1. - OKNO - nadpražie

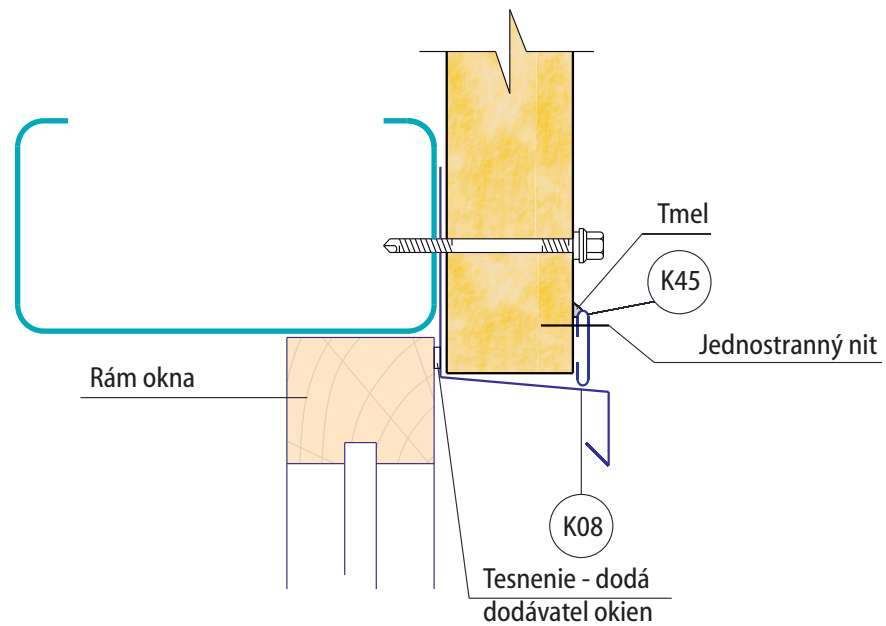

D.22.1. - OKNO - parapet

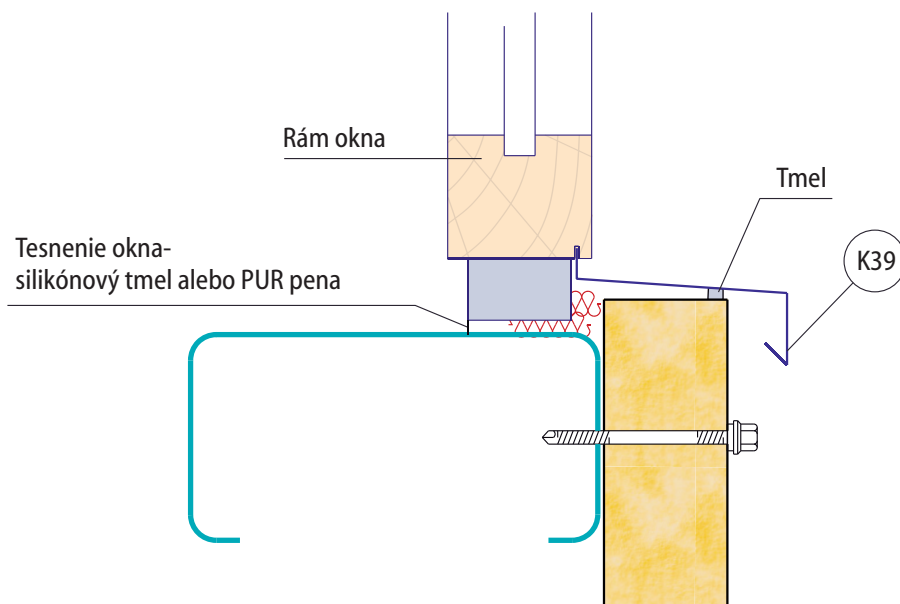

D.22.2. - OKNO - parapet

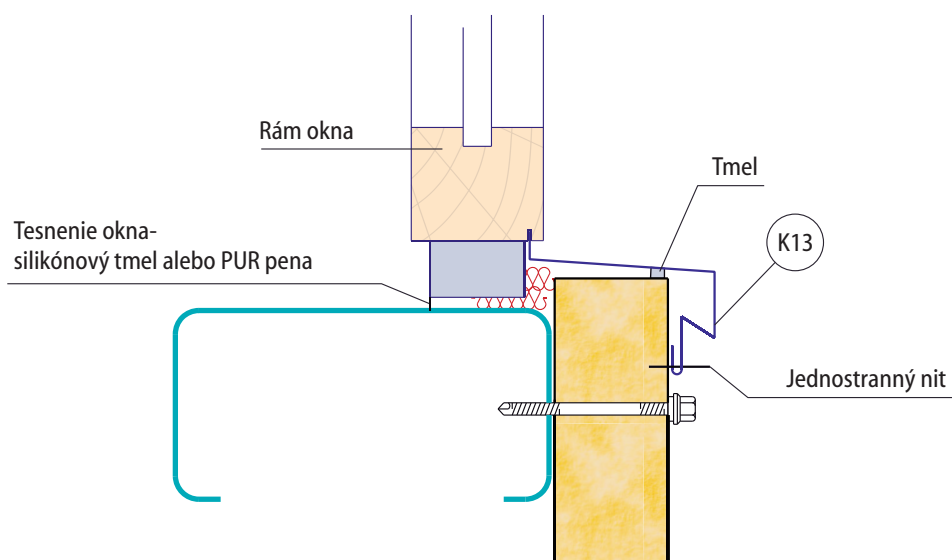

D.23.1. - OKNO - ostenie

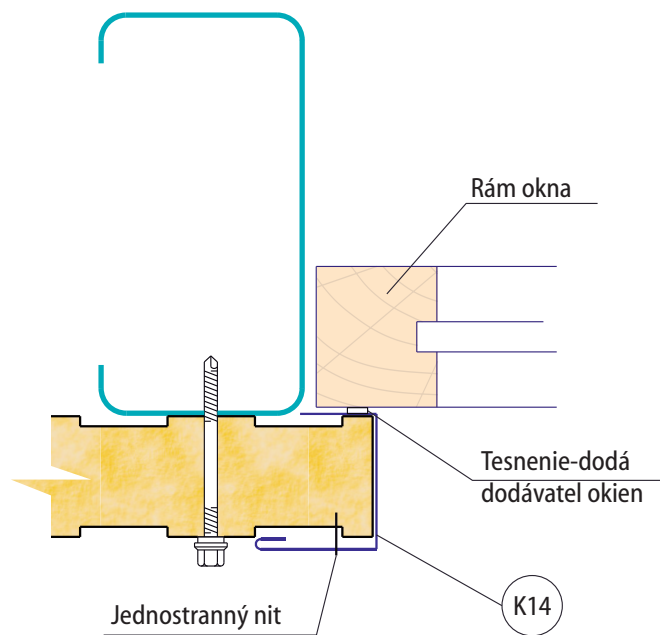

D.25.1. ROLOVACIE DVERE - nadpražie

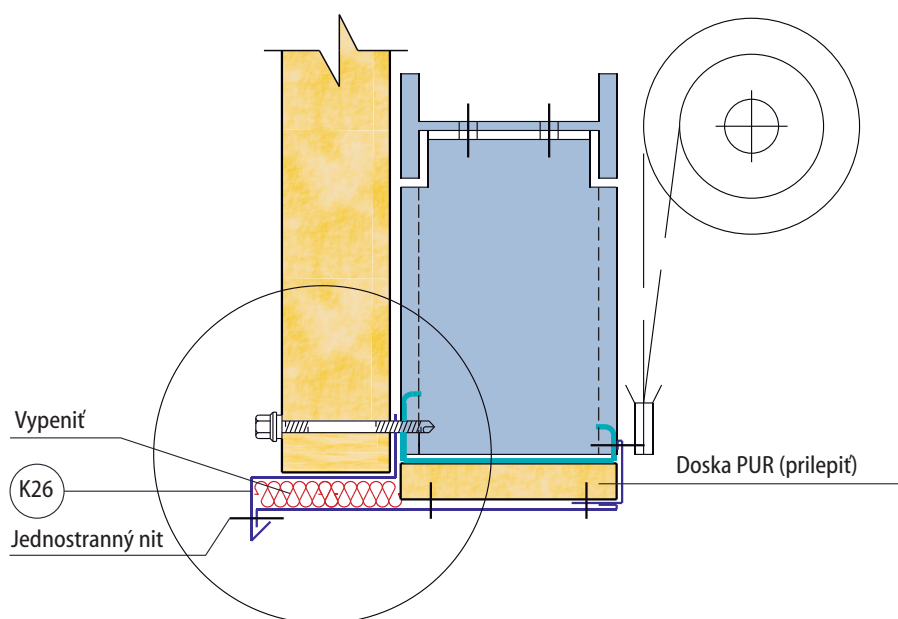

D.26.1. ROLOVACIE DVERE - ostenie

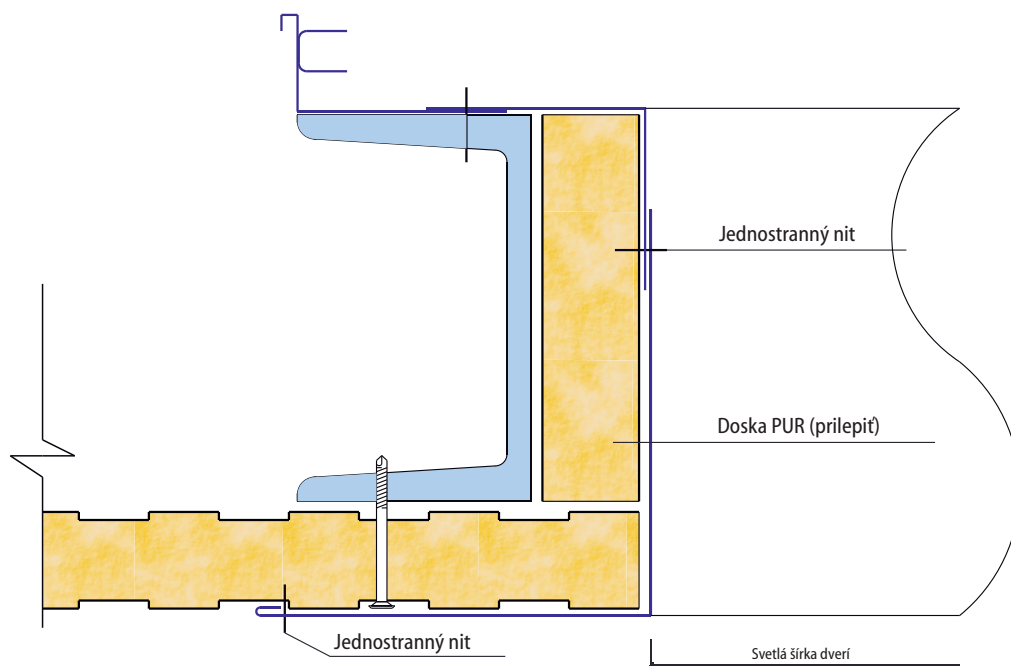

D.27.1. UCHYTENIE PRIEČOK PRI STROPE

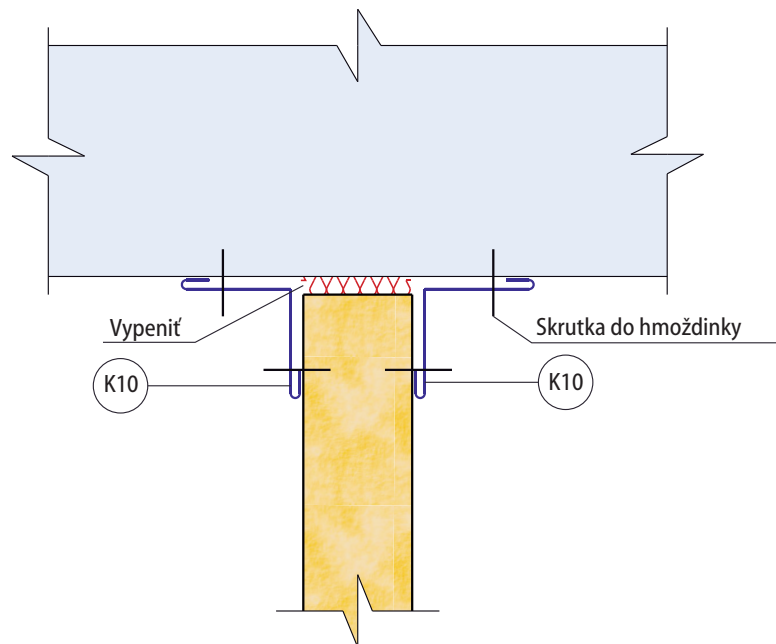

D.28.1. - UCHYTENIE PRIEČOK PRI PODLAHE

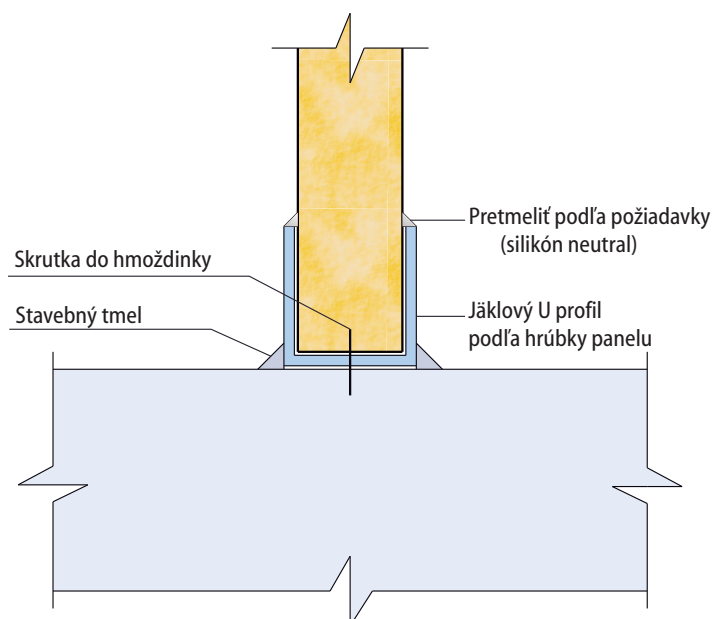

D.28.2. - UCHYTENIE PRIEČOK PRI PODLAHE

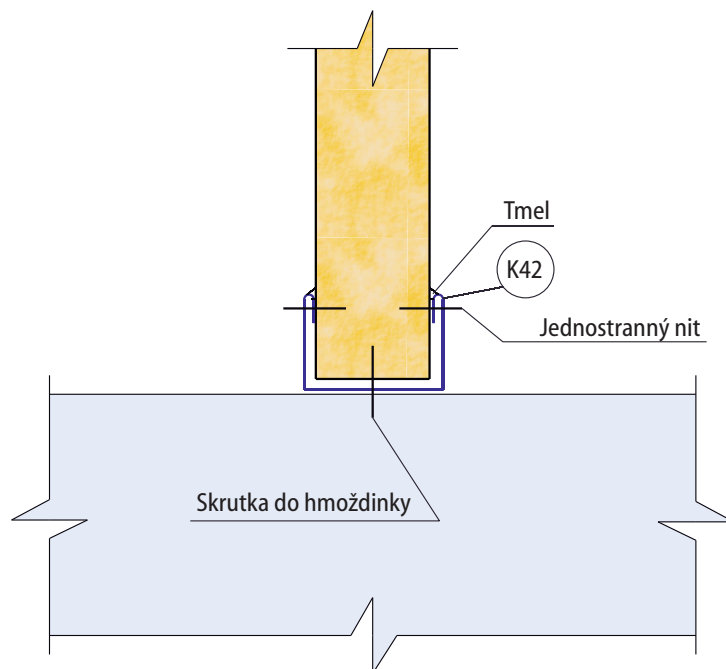

D29.1 - Spoj strešného a presvetľovacieho panela - v spáde

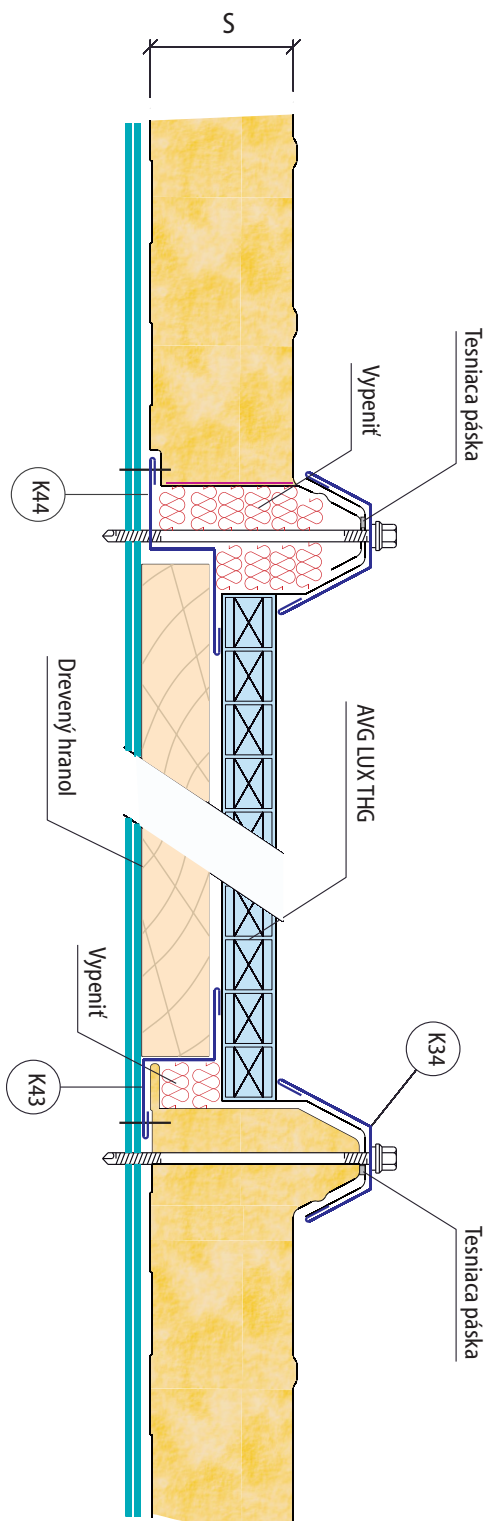

D29.2 - Spoj strešného a presvetľovacieho panela - čelný

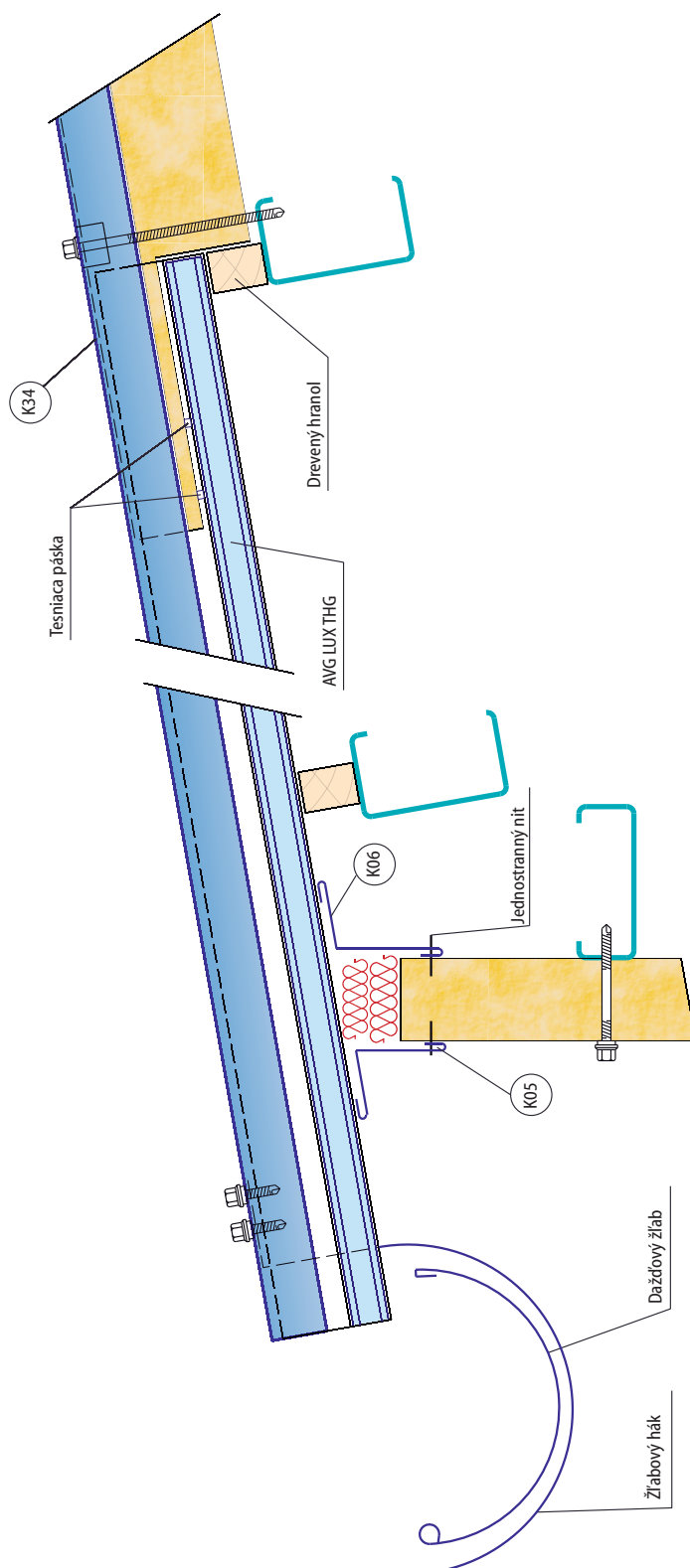

D30.1 - SPOJ STENOVÉHO A PRESVETĽOVACIEHO PANELA - NADPRAŽIE

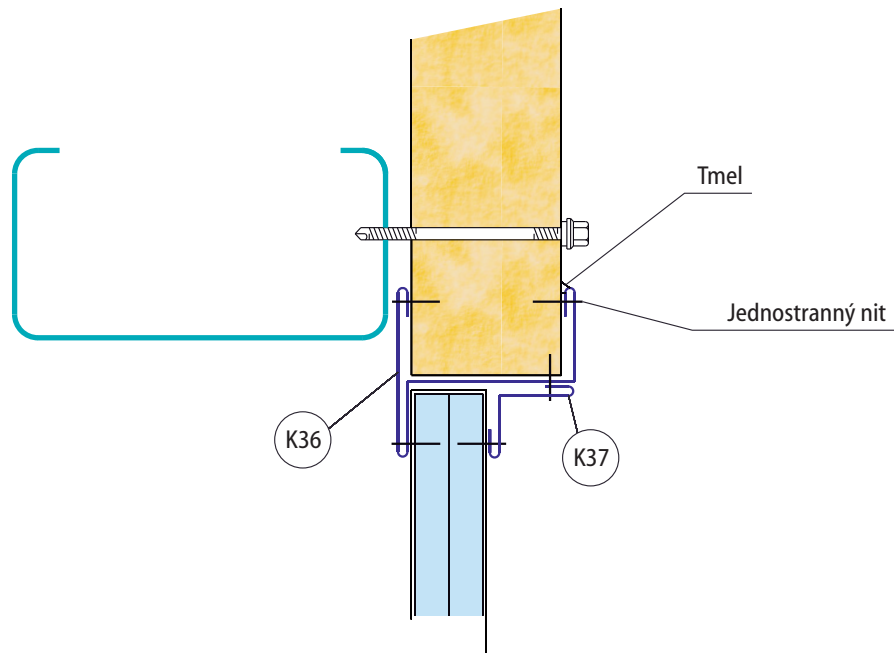

D30.2 - SPOJ STENOVÉHO A PRESVETĽOVACIEHO PANELA - PARAPET

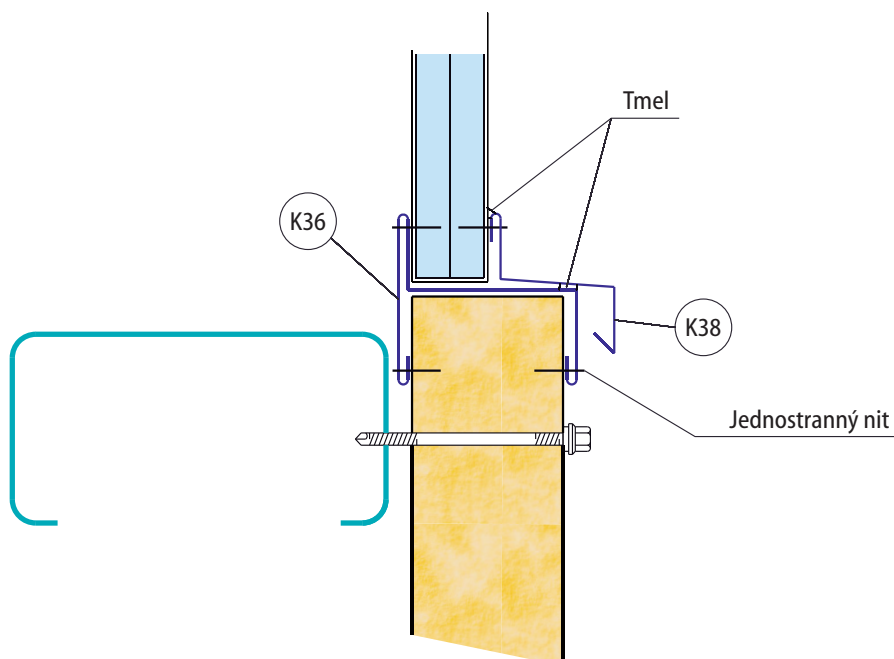

D30.3 - SPOJ STENOVÉHO A PRESVETĽOVACIEHO PANELA - OSTENIE

